

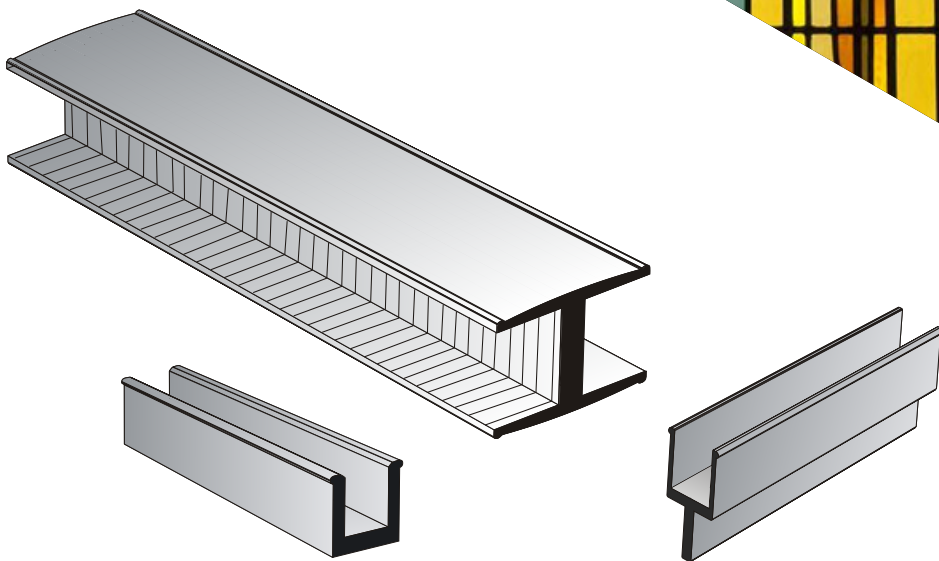

CASCADE METALS





SINCE 1971

LEAD PROGRAM
PROGRAMME PLOMB
LOOD PROGRAMMA
BLEIPROGRAMM
PROGRAMA PLOMO
PROGRAMMA PLOMBO



▶  **5%** - Tolerances - Tolérances - Toleranties
 - Toleranzen - Tolerancia -Tolleranza

▶  **3m**
 ▶  **2m**
 ▶  **1.2m** - Lengths
 - Longueurs
 - Lengten
 - Längen
 - Tiras
 - Barre

▶  **15Kg**
 ▶  **30Kg**
 ▶  **30m**
 ▶  **50m** - Rolls
 - Rouleaux
 - Rollen
 - Rollen
 - Rollos
 - Rotoli



▶ **Hardnesses :** **EXTRA-SOFT** - Extra-soft - Extra-mou - Extra-zacht
 - Extra-weich - Extra-blando - Stramorbido

Duretés :
Hardheden :
Härte : **1/2 SOFT** - 1/2 Soft - 1/2 Mou - 1/2 Zacht
 - 1/2 Weich - 1/2 Blando - 1/2 Morbido

Durezas :
Durezza : **1/2 HARD** - 1/2 Hard - 1/2 Dur - 1/2 Hart
 - 1/2 Hard - 1/2 Duro - 1/2 Duro

|| SOFT - Hard - Dur - Hart
 - Hard - Duro - Duro

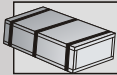
▶ **Packaging :**
Emballage :
verpakking :
Verpackung :
Embalaje :
Condizionamento :

 Wooden cases - wooden cases - caisses en bois - houten kisten - holzkisten - cajas de madera - casse in legno	 Cardboard box - cardboard box - boîtes en carton - kartonnen dozen - Kartons - cajas de cartón - casse di cartone
---	--

**1 LEAD PROFILES, LAMINATED READY FOR USE, PLAIN.
PROFILES EN PLOMB LAMINE LISSE.
GEPRESTE LODEN PROFIELEN, GLAD.
FENSTERBLEI-PROFILE, GEPRESST.
PERFILES DE PLOMO LAMINADO LISO.
PROFILATI DI PIOMBO LAMINATO LISCIO.**

<p>A In "H" section, flat. En forme de "H" plat. In "H"-vorm, vlak. In "H"-Form, flach. En forma de "H" plana. A forma di "H" piatta. _____ 6</p>	<p>H In "Y" section, flat, with centred flange. En forme de "Y" plat, avec talon centré. In "Y"-vorm, vlak, met gecentreerde tand. In "Y"-Form, flach, mit mittlerem Steg. En forma de "Y" plano, con espiga en el centro. A forma di "Y" piatta, con maschio centrato. _____ 9</p>	<p>O In "Y" section, round. En forme de "Y" rond. In "Y"-vorm, rond. In "Y"-Form, rund. En forma de "Y" redonda. A forma di "Y" rotonda. _____ 11</p>
<p>B In "H" section, flat, extra thin, extra hard. En forme de "H" plat, extra-mince, extra dur. In "H"-vorm, vlak, extra dun, extra hard. In "H"-Form, flach, extra dünn, extra hart. En forma de "H" plano, extra fino, extra duro. A forma di "H" piatta, extra sottile, extra duro. _____ 6</p>	<p>I In "Y" section, flat, with lateral flange. En forme de "Y" plat, avec talon latéral. In "Y"-vorm, vlak, met zijdelingse tand. In "Y"-Form, flach, mit seitlichem Steg. En forma de "Y" plano, con espiga lateral. A forma di "Y" piatta, con maschio laterale. _____ 9</p>	<p>P In "H" section, flat, CRF. En forme de "H" plat, CRF. In "H"-vorm, vlak, CRF. In "H"-Form, flach, CRF. En forma de "H" plana, CRF. A forma di "H" piatta, CRF. _____ 12</p>
<p>C In "H" section, oval. En forme de "H" oval. In "H"-vorm, ovaal. In "H"-Form, oval. En forma de "H" oval. A forma di "H" ovale. _____ 6</p>	<p>J In "H" section, flat, off-centred core. En forme de "H" plat, avec âme décentrée. In "H"-vorm, vlak, met gedecentreerde ziel. In "H"-Form, flach, mit dezentriertem kern. En forma de "H" plana, con alma descentrada. A forma di "H" piatta, con anima laterale. _____ 10</p>	<p>Q Lead for lanterns. Plomb lanterne. Lantaarnlood. Laternenblei. Plomo para faroles. Piombo per applique. _____ 12</p>
<p>D In "U" section, flat. En forme de "U" plat. In "U"-vorm, vlak. In "U"-Form, flach. En forma de "U" plana. A forma di "U" piatta. _____ 7</p>	<p>K In "T" section, flat. En forme de "T" plat. In "T"-vorm, vlak. In "T"-Form, flach. En forma de "T" plana. A forma di "T" piatta. _____ 10</p>	<p>R Lead rods. Baguettes de plomb. Loodstaafjes. Bleistäbe. Varillas de plomo. Bacchette di piombo. _____ 13</p>
<p>E In "U" section, HEAVY. En forme de "U" LOURD. In "U"-vorm, ZWAAR. In "U"-Form, SCHWER. En forma de "U" PESADO. A forma di "U" PESANTE. _____ 7</p>	<p>L In "C" section, round. En forme de "C" rond. In "C"-vorm, rond. In "C"-Form, rund. En forma de "C" redonda. A forma di "C" rotonda. _____ 10</p>	<p>S Jointing-lead. Plomb attache. Bindlood. Haftenblei. Plomo de juntura. Piombo per giuntatura. _____ 13</p>
<p>F In "U" section, DV. En forme de "U" DV. In "U"-vorm, DV. In "U"-Form, DV. En forma de "U" DV. A forma di "U" DV. _____ 8</p>	<p>M In "C" section, CAN (Fluted). En forme de "C" CAN (Cannelé). In "C"-vorm, CAN (Gegolfd). In "C"-Form, CAN (Kanneliert). En forma de "C" CAN (Acanalado). A forma di "C" CAN (Scanalato). _____ 11</p>	<p>T "PLL". _____ 13</p>
<p>G In "U" section, CRF, with hollow core. En forme de "U" CRF, âme creuse. In "U"-vorm, CRF, met holle ziel. In "U"-Form, CRF, mit Hohlkern. En forma de "U" CRF, con alma hueca. A forma di "U" CRF, con anima vuota. _____ 8</p>	<p>N In "H" section, round. En forme de "H" rond. In "H"-vorm, rond. In "H"-Form, rund. En forma de "H" redonda. A forma di "H" rotonda. _____ 11</p>	

**2 LEAD PROFILES, READY FOR USE, RIBBED.
PROFILES EN PLOMB ETIRE RAINURE.
GETROKKEN LODEN PROFIELEN, GERIBD.
FENSTERBLEI-PROFILE, GEZOGEN, GERILLT.
PERFILES DE PLOMO ESTIRADO RANURADO.
PROFILATI DI PIOMBO TRAFILATO RIGATO.**

<p>A In "H" section, flat. En forme de "H" plat. In "H"-vorm, vlak. In "H"-Form, flach. En forma de "H" plana. A forma di "H" piatta. _____ 14</p>	<p>C In "H" section, BOR. En forme de "H" BOR. In "H"-vorm, BOR. In "H"-Form, BOR. En forma de "H" BOR. A forma di "H" BOR. _____ 16</p>
<p>B In "H" section, oval. En forme de "H" oval. In "H"-vorm, ovaal. In "H"-Form, oval. En forma de "H" oval. A forma di "H" ovale. _____ 15</p>	<p>D In "H" section, antique design. En forme de "H" antique. In "H"-vorm, antiek. Karniesblei in "H"-Form. En forma de "H" antiguo. A forma di "H" antico. _____ 16</p>

3

REINFORCED LEAD PROFILES, LAMINATED, READY FOR USE, PLAIN, with hardened or non-hardened steel wire.

PROFILES EN PLOMB ARME, LAMINE LISSE, avec fil d'acier trempé ou non trempé.

GEbruIKSKLARE PROFIELEN IN GEWAPEND LOOD, GLAD, met geharde of niet-geharde staaldraad.

STAHLKERNBLEI, GLATT, mit gehärteter oder ungehärterter Stahldraht.

PERFILES DE PLOMO, ARMADO, LAMINADO LISO, con alambre de acero, templado o no.

PROFILATI DI PIOMBO ARMATO, LAMINATO LISCIO, con filo d'acciaio temperato o no.

A Flat reinforced lead (steel wire of 4 x 1.5mm).
Plomb armé plat (fil d'acier de 4 x 1.5mm).
Vlak gewapend lood (staaldraad van 4 x 1.5mm).
Flaches Stahlkernblei (Stahleinlage von 4 x 1.5mm).
Plomo armado plano (con alambre de acero de 4 x 1.5mm).
Piombo armato piatto (filo d'acciaio da 4 x 1.5mm). _____ 17

B Oval reinforced lead (steel wire of 4 x 1.5mm).
Plomb armé oval (fil d'acier de 4 x 1.5mm).
Ovaal gewapend lood (staaldraad van 4 x 1.5mm).
Ovales Stahlkernblei (Stahleinlage von 4 x 1.5mm).
Plomo armado oval (con alambre de acero de 4 x 1.5mm).
Piombo armato ovale (filo d'acciaio da 4 x 1.5mm). _____ 17

C Reinforced lead, strengthened (steel wire of 5 x 2mm).
Plomb armé renforcé (fil d'acier de 5 x 2mm).
Versterkt gewapend lood (staaldraad van 5 x 2mm).
Verstärktes Stahlkernblei (Stahleinlage von 5 x 2mm).
Plomo armado reforzado (con alambre de acero de 5 x 2mm).
Piombo armato rafforzato (filo d'acciaio da 5 x 2mm). _____ 17

D Antique reinforced lead (steel wire of 4 x 1.5mm).
Plomb armé antique (fil d'acier de 4 x 1.5mm).
Antiek gewapend lood (staaldraad van 4 x 1.5mm).
Karnies Stahlkernblei (Stahleinlage von 4 x 1.5mm).
Plomo armado antiguo (con alambre de acero de 4 x 1.5mm).
Piombo armato antico (filo d'acciaio da 4 x 1.5mm). _____ 18

E Reinforced lead in "U" section, HEAVY (steel wire of 4 x 1.5mm).
Plomb armé, en forme de "U" LOURD (fil d'acier de 4 x 1.5mm).
Gewapend lood in "U"-vorm, ZWAAR (staaldraad van 4 x 1.5mm).
Stahlkernblei in "U"-Form, SCHWER (Stahleinlage von 4 x 1.5mm).
Plomo armado en forma de "U" PESADO (alambre de acero de 4 x 1.5mm).
Piombo armato a forma di "U" PESANTE (filo d'acciaio da 4 x 1.5mm). _____ 18

F Round iron rods covered with plain lead.
Vergettes rondes en acier recouvertes de plomb lisse.
Ronde stalen roeden overtrokken met glad lood.
Runde Windeisen aus Stahl mit Bleiüberzug.
Varillas redondas de acero revestidas con plomo liso.
Verghette rotonde d'acciaio ricoperte di piombo liscio. _____ 18

4

ROUGH SOLID LEAD PROFILES.

PROFILES EBAUCHE EN PLOMB LISSE.

BRUKLOOD, GLAD.

BRUCHBLEI, GEPRESST.

PERFILES DE PLOMO BRUTO MACIZO, LISO.

PROFILATI DI PIOMBO GREZZO LISCIO.

A Rough solid lead profiles, plain execution.
Profils ébauche en plomb lisse, plein.
Vol breuklood, glad.
Volles bruchblei, gepresst.
Perfiles de plomo bruto macizo, liso.
Profilati di piombo grezzo liscio, pieno. _____ 19

B Plain rough lead profiles, with hollow core.
Profils ébauche en plomb lisse, à âme creuse.
Breuklood, glad, met holle ziel.
Bruchblei mit hohlkern, gepresst.
Perfiles de plomo bruto macizo, liso, con alma hueca.
Profilati di piombo grezzo liscio, con anima vuota. _____ 19

C Hardened or non-hardened steel wire.
Fil d'acier trempé ou non trempé.
Geharde of niet-geharde staaldraad.
Gehärteter oder ungehärterter Stahldraht.
Alambre de acero, templado o no.
Filo d'acciaio temperato o no. _____ 20

5

Tin-solder.

Soudure d'étain.

Tinsoldeer.

Lötzinn.

Soldadura de estaño.

Stagno.

A Plain tin-solder.
Soudure d'étain lisse.
Tinsoldeer glad.
Lötzinn glatt.
Soldadura de estaño liso.
Stagno liscio. _____ 20

B Ribbed tin-solder.
Soudure d'étain rainurée.
Geribd tinsoldeer.
Lötzinn gerillt.
Soldadura de estaño ranurado.
Stagno rigato. _____ 20

6

LEAD STRIPS (with or without adhesive tape).

BANDES DE PLOMB (avec ou sans bande adhésive).

LOODSTRIPS (met of zonder kleefband).

BLEIBÄNDER (mit oder ohne Klebeband).

BANDAS DE PLOMO (con o sin autopegante).

STRISCE DI PIOMBO (con o senza adesivo).

A Lead strips "Flat".
Bandes de plomb "Plat".
Loodstrips "Vlak".
Bleibänder "Flach".
Bandas de plomo "Plano".
Strisce di piombo "Piatta". _____ 21

B Lead strips "Half-round".
Bandes de plomb "Demi rond".
Loodstrips "Halfrond".
Bleibänder "Halbrund".
Bandas de plomo "Semi redondo".
Strisce di piombo "Mezzo tondo". _____ 21

C Lead strips "CAN" (Fluted).
Bandes de plomb "CAN" (Cannelé).
Loodstrips "CAN" (Gegolfd).
Bleibänder "CAN" (Kanneliert).
Bandas de plomo "CAN" (Acanalado).
Strisce di piombo "CAN" (Scanalato). _____ 22

7

PLAIN LEAD PROFILES, COATED WITH BRASS, RED COPPER, GERMAN SILVER AND ANODISED OR LACQUERED ALUMINIUM .
PROFILES EN PLOMB LISSE RECOUVERTS DE LAITON, CUIVRE ROUGE, MAILLECHORT ET D'ALUMINIUM ANODISE OU LAQUE.
LODEN PROFIELEN, GLAD, OVERTROKKEN MET MESSING, ROODKOPER, NIEUWZILVER EN GEANODISEERD OF GELAKT ALUMINIUM.
BLEIPROFILE, GEPRESST, MIT MESSING-, ROTKUPFER-, NEUSILBERÜBERZUG UND ELOXIERTEM ODER LACKIERTEM ALUMINIUMÜBERZUG.
PERFILES DE PLOMO LISO, REVESTIDOS CON LATÓN, COBRE ROJO, PLATA ALEMANA Y ALUMINIO ANODIZADO O LACADO.
PROFILATI DI PIOMBO LISCIO RICOPERTI DI OTTONE, RAME ROSSO, ALPACCA ED ALLUMINIO ANODIZZATO O LACCATO.

A In "H" section, oval (1 - 11).
En forme de "H" oval (1 - 11).
In "H"-vorm, ovaal (1 - 11).
In "H"-Form, oval (1 - 11).
En forma de "H" oval (1 - 11).
A forma di "H" ovale (1 - 11). _____ 24

B In "Y" section, oval (with lead flange) (1 - 11).
En forme de "Y" oval (talon plomb) (1 - 11).
In "Y"-vorm, ovaal (loden tand) (1 - 11).
In "Y"-Form, oval (mit bleisteg) (1 - 11).
En forma de "Y" oval (con espiga de plomo) (1 - 11).
A forma di "Y" ovale (maschio di piombo) (1 - 11). _____ 25

C In "C" section, oval.
En forme de "C" oval.
In "C"-vorm, ovaal.
In "C"-Form, oval.
En forma de "C" oval.
A forma di "C" ovale. _____ 25

D In "Y" section, flat.
En forme de "Y" plat.
In "Y"-vorm, vlak.
In "Y"-Form, flach.
En forma de "Y" plano.
A forma di "Y" piatta. _____ 26

E In "U" section, flat.
En forme de "U" plat.
In "U"-vorm, vlak.
In "U"-Form, flach.
En forma de "U" plano.
A forma di "U" piatta. _____ 26

F In "Y" section, oval.
En forme de "Y" oval.
In "Y"-vorm, ovaal.
In "Y"-Form, oval.
En forma de "Y" oval.
A forma di "Y" ovale. _____ 26

G In "H" section, flat (1 - 11).
En forme de "H" plat (1 - 11).
In "H"-vorm, vlak (1 - 11).
In "H"-Form, flach (1 - 11).
En forma de "H" plano (1 - 11).
A forma di "H" piatta (1 - 11). _____ 27

H Lead for lanterns.
Plomb lanterne.
Lantaarnlood.
Laternenblei.
Plomo para faroles.
Piombo per applique. _____ 27

I In "Y" section, round.
En forme de "Y" rond.
In "Y"-vorm, rond.
In "Y"-Form, rund.
En forma de "Y" redonda.
A forma di "Y" rotonda. _____ 28

J Lead strips ("Flat"/"Half-round")
Bandes de plomb ("Plat"/"Demi rond").
Loodstrips ("Vlak"/"Halfrond").
Bleibänder ("Flach"/"Halbrund").
Bandas de plomo ("Plano"/"Semi redondo").
Strisce di piombo
("Piatta"/"Mezzo tondo"). _____ 28

8

PLAIN LEAD PROFILES, WITH "BI-METALLIC" COATING.
PROFILES EN PLOMB LISSE AVEC RECOUVREMENT "BI-METAL".
LODEN PROFILEN, GLAD, "BI-METAAL" OVERTROKKEN.
BLEIPROFILE, GEPRESST, MIT "BIMETALL" -ÜBERZUG.
PERFILES DE PLOMO LISO, CON REVESTIMIENTO "BI-METALICO".
PROFILATI DI PIOMBO LISCIO CON RICOPRIMENTO "BI-METALLICO".

A In "H" section, oval.
En forme de "H" oval.
In "H"-vorm, ovaal.
In "H"-Form, oval.
En forma de "H" oval.
A forma di "H" ovale. _____ 29

B In "Y" section, oval.
En forme de "Y" oval.
In "Y"-vorm, ovaal.
In "Y"-Form, oval.
En forma de "Y" oval.
A forma di "Y" ovale. _____ 29

9

METAL CONTOUR PROFILES.
PROFILES METALLIQUES DE CONTOUR.
METALEN RANDPROFIELEN.
METALLRANDPROFILE.
PERFILES METALICOS DE CONTORNO.
PROFILATI METALLICI DI CONTORNO.

A Tinplate "U" profiles in 2m length.
"U" en fer blanc; en 2m.
"U" - profielen in blik in 2m.
"U"- Leisten aus Weissblech, in 2m.
"U" de hojalata, en largos de 2m.
"U" in barre da 2m. _____ 30

B "U" profiles in raw brass, red copper, or german silver, in 2m length.
"U" en laitton brut, cuivre rouge ou maillechort, en 2m.
"U" - profielen in ruw messing, roodkoper of nieuwzilver, in 2m.
"U" - Leisten aus Rohmessing, Rotkupfer, oder Neusilber, in 2m.
"U" de latón bruto, cobre rojo o plata alemana, en largos de 2m.
"U" in ottone, rame rosso o alpacca in barre da 2m. _____ 30

C "U" and "T" profiles in zinc, raw brass, red copper.
"U" et "T" en zinc, laitton brut, cuivre rouge.
"U" en "T" - profielen in zink, ruw messing, roodkoper.
"U" and "T" - Leisten aus Zink, Rohmessing, Rotkupfer.
"U" o "T" de zinc, latón bruto, cobre rojo.
"U" o "T" in zinco, ottone, rame rosso. _____ 30

10

PACKAGING.
CONDITIONNEMENT.
VERPAKKING.
VERPACKUNG.
EMBALAJE.
CONDIZIONAMENTO.

A Normal packaging.
Conditionnement normal.
Normale verpakking.
Normale Verpackung.
Embalaje corriente.
Condizionamento corrente. _____ 31

B Special packaging for distributors.
Conditionnement spécial pour distributeurs.
Speciale verpakking voor verdelers.
Sonderverpackung für groshändler.
Embalaje especial para distribuidores.
Condizionamento speciale per distributori. _____ 31

A

In "H" section, flat.
 En forme de "H" plat.
 In "H"-vorm, vlak.
 In "H"-Form, flach.
 En forma de "H" plana.
 A forma di "H" piatta.

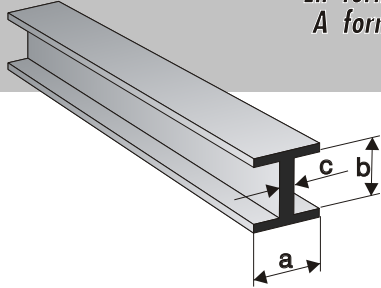

"H" a x b x c PL

5%
 2m
 Wooden cases
 1/2 SOFT
 1/2 HARD
 HARD

a (mm)	b (mm)	c (mm)	Weight Poids Gewicht Gewicht Peso Peso (gr/m)	Category Catégorie Categorie Kategorie Categoria Categoria
4	3	1.2	90	1
4	4	1.2	105	1
6	3	1.2	110	2
6	3.5	1.2	115	2
6	4	1.2	125	2
6	4.5	1.2	135	2
6	5	1.2	145	2
7	3	1.2	125	3
7	3.5	1.2	130	3
7	4	1.2	140	3
7	4.5	1.2	150	3
7	5	1.2	160	3
8	2.2	1.2	120	2
8	3	1.2	135	3
8	3.5	1.2	140	3
8	4	1.2	145	3
8	4.5	1.2	155	3
8	5	1.2	170	3
10	4	1.2	175	4
10	4.5	1.2	185	4
10	5	1.2	190	4
10	8	1.2	250	4
26	5	2	665	4

B

In "H" section, flat, extra thin, extra hard.
 En forme de "H" plat, extra-mince, extra dur.
 In "H"-vorm, vlak, extra dun, extra hard.
 In "H"-Form, flach, extra dünn, extra hart.
 En forma de "H" plano, extra fino, extra duro.
 A forma di "H" piatta, extra sottile, extra duro.

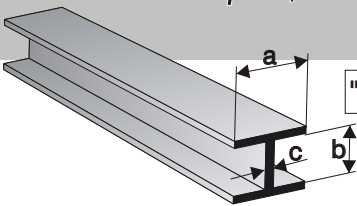

"H" a x b x c PLM

5%
 2m
 Wooden cases

a (mm)	b (mm)	c (mm)	Weight Poids Gewicht Gewicht Peso Peso (gr/m)	Category Catégorie Categorie Kategorie Categoria Categoria
5	4	0.7	85	1
6	3	0.7	100	1
6	4	0.7	110	2
6	4.5	0.7	115	2
8	4	0.7	130	3

C

In "H" section, oval.
 En forme de "H" oval.
 In "H"-vorm, ovaal.
 In "H"-Form, oval.
 En forma de "H" oval.
 A forma di "H" oval.

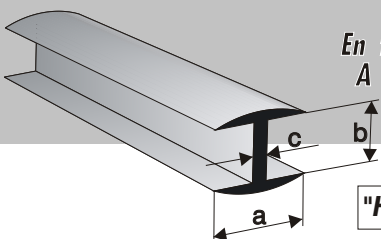

"H" a x b x c OV

5%
 2m
 Wooden cases
 1/2 SOFT
 1/2 HARD
 HARD

a (mm)	b (mm)	c (mm)	Weight Poids Gewicht Gewicht Peso Peso (gr/m)	Category Catégorie Categorie Kategorie Categoria Categoria
5	3	1.2	146	3
5	4	1.2	158	3

**LEAD PROFILES, LAMINATED READY FOR USE, PLAIN.
 PROFILES EN PLOMB LAMINE LISSE.
 GEPRESTE LODEN PROFIELEN, GLAD.
 FENSTERBLEI-PROFILE, GEPRESST.
 PERFILES DE PLOMO LAMINADO LISO.
 PROFILATI DI PIOMBO LAMINATO LISCIIO.**

1

D

a (mm)	b (mm)	Weight Poids Gewicht Peso (gr/m)	Category Catégorie Categorie Kategorie Categoria
4	3.5	90	1
4	4	100	1
5	2.2	93	1
5	4	115	1
5	5	130	1
6	4	125	2
6	4.5	135	2
6	5	140	2
6	6	150	2
8	4	150	3
8	5	160	3
8	6.5	176	4
10	4	176	4
10	5	195	4

In "U" section, flat.
 En forme de "U" plat.
 In "U"-vorm, vlak.
 In "U"-Form, flach.
 En forma de "U" plana.
 A forma di "U" piatta.

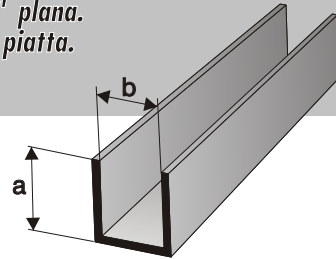

"U" a x b PL

5%
 2m
 Wooden cases
 1/2 SOFT
 1/2 HARD
 HARD

E

a (mm)	b (mm)	c (mm)	Weight Poids Gewicht Peso (gr/m)	Category Catégorie Categorie Kategorie Categoria
4	3.5	1.2	135	3
8	4.5	1.2	205	4
8	5	1.2	224	4
10	5	1.2	265	4
7	5	4	338	4
8	5	4	410	4
19	3	14	880	4
20	5	12	1130	4

In "U" section, HEAVY.
 En forme de "U" LOURD.
 In "U"-vorm, ZWAAR.
 In "U"-Form, SCHWER.
 En forma de "U" PESADO.
 A forma di "U" PESANTE.

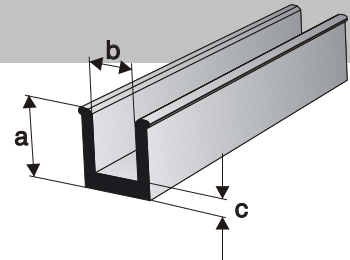

"U" Lourd a x b x c

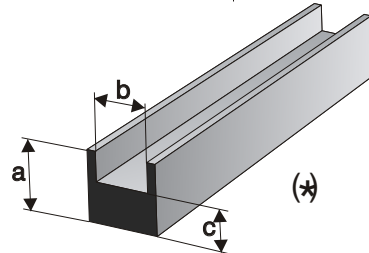

5%
 2m
 Wooden cases
 1/2 SOFT
 1/2 HARD
 HARD

F

In "U" section, DV.
 En forme de "U" DV.
 In "U"-vorm, DV.
 In "U"-Form, DV.
 En forma de "U" DV.
 A forma di "U" DV.

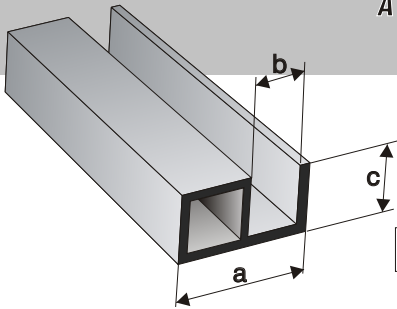

"U" a x b x c DV

a	b	c	Weight Poids Gewicht Peso Peso	Category Catégorie Categoria Kategorie Categoria
(mm)	(mm)	(mm)	(gr/m)	
13	5	7	385	4
19	6.5	8	530	4

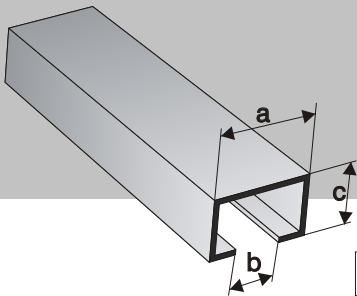

"U" a x b x c DV

a	b	c	Weight Poids Gewicht Peso Peso	Category Catégorie Categoria Kategorie Categoria
(mm)	(mm)	(mm)	(gr/m)	
11	5	7	190	3



5%



2m



Wooden cases



1/2 SOFT



1/2 HARD



HARD

G

In "U" section, CRF, with hollow core.
 En forme de "U" CRF, âme creuse.
 In "U"-vorm, CRF, met holle ziel.
 In "U"-Form, CRF, mit Hohlkern.
 En forma de "U" CRF, con alma hueca.
 A forma di "U" CRF, con anima vuota.

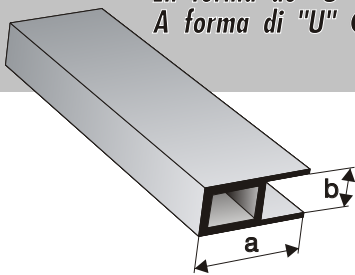

"U" a x b CRF

a	b	Weight Poids Gewicht Peso Peso	Category Catégorie Categoria Kategorie Categoria
(mm)	(mm)	(gr/m)	
12	4.5	290	4

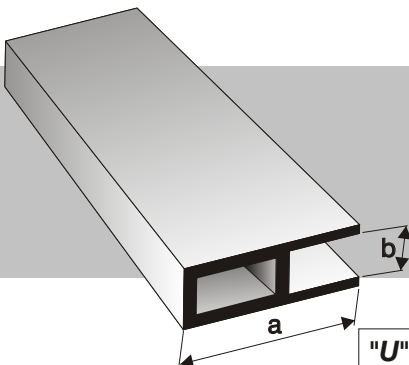

HEAVY
 LOURD
 ZWAAR
 SCHWER
 PESADO
 PESANTE

"U" Lourd a x b CRF

a	b	Weight Poids Gewicht Peso Peso	Category Catégorie Categoria Kategorie Categoria
(mm)	(mm)	(gr/m)	
20	5	792	4



5%



2m



Wooden cases



1/2 SOFT



1/2 HARD



HARD

**LEAD PROFILES, LAMINATED READY FOR USE, PLAIN.
 PROFILES EN PLOMB LAMINE LISSE.
 GEPRESTE LODEN PROFIELLEN, GLAD.
 FENSTERBLEI-PROFILE, GEPRESST.
 PERFILES DE PLOMO LAMINADO LISO.
 PROFILATI DI PIOMBO LAMINATO LISCIO.**

1

In "Y" section, flat, with centred flange.
 En forme de "Y" plat, avec talon centré.
 In "Y"-vorm, vlak, met gecentreerde tand.
 In "Y"-Form, flach, mit mittlerem Steg.
 En forma de "Y" plana, con espiga en el centro.
 A forma di "Y" piatta, con maschio centrato.

H

a (mm)	b (mm)	h (mm)	Weight Poids Gewicht Gewicht Peso Peso (gr/m)	Category Catégorie Categoria Categoria Categoria Categoria Categoria
5	3.5	6	185	3
5	4	6	200	3
8	3	6	220	4
8	4	6	240	4
8	5	6	250	4
10	5	6	280	4

"Y" a x b x h PL

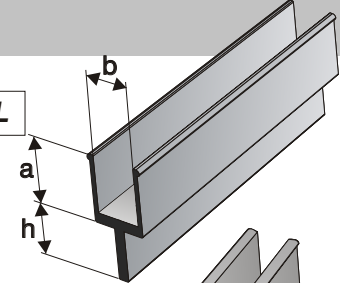

a (mm)	b (mm)	h (mm)	Weight Poids Gewicht Gewicht Peso Peso (gr/m)	Category Catégorie Categoria Categoria Categoria Categoria Categoria
8	5	6	305	4
10	5	6	335	4

**HEAVY
 LOURD
 ZWAAR
 SCHWER
 PESADO
 PESANTE**

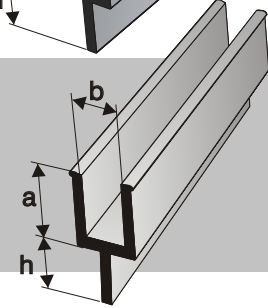

"Y" Lourd a x b x h PL

5%
 2m
 Wooden cases
 1/2 SOFT
 1/2 HARD
 HARD

In "Y" section, flat, with lateral flange.
 En forme de "Y" plat, avec talon latéral.
 In "Y"-vorm, vlak, met zijdelingse tand.
 In "Y"-Form, flach, mit seitlichem Steg.
 En forma de "Y" plana, con espiga lateral.
 A forma di "Y" piatta, con maschio laterale.

I

a (mm)	b (mm)	h (mm)	Weight Poids Gewicht Gewicht Peso Peso (gr/m)	Category Catégorie Categoria Categoria Categoria Categoria Categoria
8	5	16	280	4
8	5	22	360	4

"Y" a x b x h PL

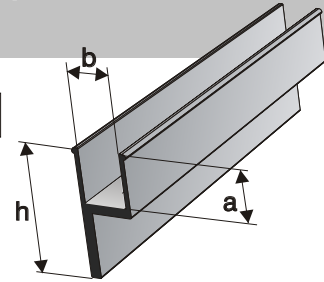

a (mm)	b (mm)	h (mm)	Weight Poids Gewicht Gewicht Peso Peso (gr/m)	Category Catégorie Categoria Categoria Categoria Categoria Categoria
6	3	9	445	4
6	4	9	460	4

**HEAVY
 LOURD
 ZWAAR
 SCHWER
 PESADO
 PESANTE**

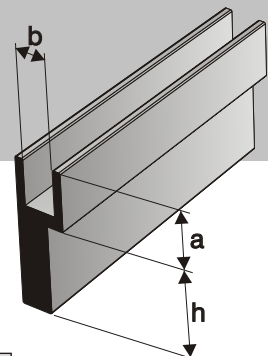

"Y" Lourd a x b x h PL

5%
 2m
 Wooden cases
 1/2 SOFT
 1/2 HARD
 HARD

J

In "H" section, flat, off-centred core.
 En forme de "H" plat, avec âme décentrée.
 In "H"-vorm, vlak, met gedecentreerde ziel.
 In "H"-Form, flach, mit dezentriertem kern.
 En forma de "H" plana, con alma descentrada.
 A forma di "H" piatta, con anima laterale.

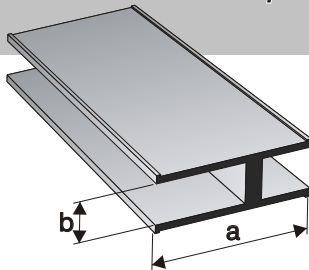

"H" a x b PL

a (mm)	b (mm)	Weight Poids Gewicht Gewicht Peso Peso (gr/m)	Category Catégorie Catégorie Kategorie Categoria Categoria
19	5	465	4

5%
 2m
 Wooden cases
 1/2 SOFT
 1/2 HARD
 HARD

K

In "T" section, flat.
 En forme de "T" plat.
 In "T"-vorm, vlak.
 In "T"-Form, flach.
 En forma de "T" plana.
 A forma di "T" piatta.

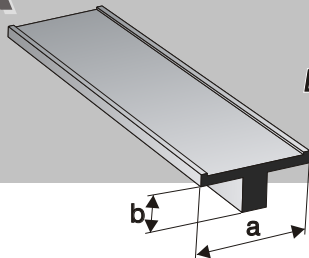

"T" a x b PL

a (mm)	b (mm)	Weight Poids Gewicht Gewicht Peso Peso (gr/m)	Category Catégorie Catégorie Kategorie Categoria Categoria
9	2.9	102	1

5%
 2m
 Wooden cases
 1/2 SOFT
 1/2 HARD
 HARD

L

In "C" section, round.
 En forme de "C" rond.
 In "C"-vorm, rond.
 In "C"-Form, rund.
 En forma de "C" redonda.
 A forma di "C" rotonda.

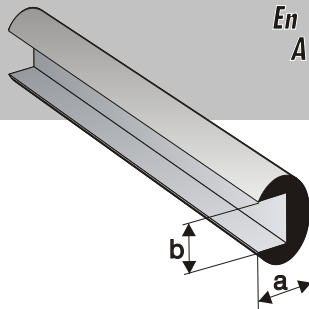

"C" a x b RD

a (mm)	b (mm)	Weight Poids Gewicht Gewicht Peso Peso (gr/m)	Category Catégorie Catégorie Kategorie Categoria Categoria
2	3.5	84	1
3.5	2	100	1
3.5	2.5	102	1
4	3.5	132	2
4.5	4	149	3
6	3.5	255	4
6	4	276	4

Re

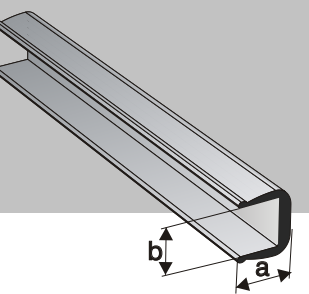

"C" a x b RD

a (mm)	b (mm)	Weight Poids Gewicht Gewicht Peso Peso (gr/m)	Category Catégorie Catégorie Kategorie Categoria Categoria
5	3	110	2
5	4	120	2
5	5	130	2

5%
 2m
 Wooden cases
 Re 15Kg
 Cardboard box
 1/2 SOFT
 1/2 HARD
 HARD

In "C" section, CAN (Fluted).

En forme de "C" CAN (Cannelé).

In "C"-vorm, CAN (Gegolfd).

In "C"-Form, CAN (Kanneliert).

En forma de "C" CAN (Acanalado).

A forma di "C" CAN (Scanalato).

M

a (mm)	b (mm)	Weight Poids Gewicht Peso Peso (gr/m)	Category Catégorie Kategorie Kategorie Categoría Categoría
8	4	590	4

"C" a x b CAN

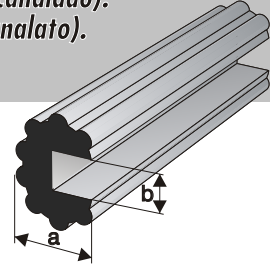

In "H" section, round.

En forme de "H" rond.

In "H"-vorm, rond.

In "H"-Form, rund.

En forma de "H" redonda.

A forma di "H" rotonda.

N

a (mm)	b (mm)	Weight Poids Gewicht Peso Peso (gr/m)	Category Catégorie Kategorie Kategorie Categoría Categoría
4	4	140	3
6	4	250	4

"H" a x b RD

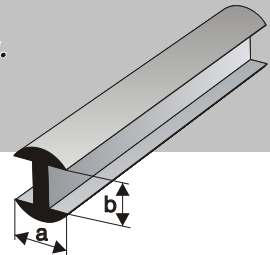

In "Y" section, round.

En forme de "Y" rond.

In "Y"-vorm, rond.

In "Y"-Form, rund.

En forma de "Y" redonda.

A forma di "Y" rotonda.

O

a (mm)	b (mm)	Weight Poids Gewicht Peso Peso (gr/m)	Category Catégorie Kategorie Kategorie Categoría Categoría
8	4.5	400	4

"Y" a x b RD

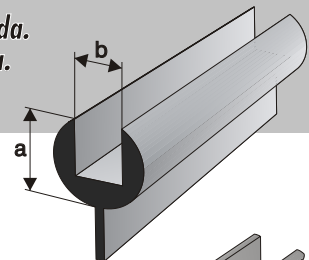

a (mm)	b (mm)	h (mm)	Weight Poids Gewicht Peso Peso (gr/m)	Category Catégorie Kategorie Kategorie Categoría Categoría
8	5	30	468	4

"Y" a x b x h RD

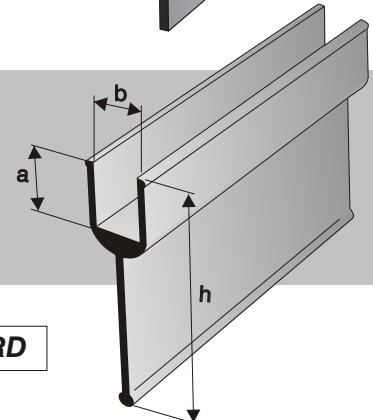

P

In "H" section, flat, CRF.
 En forme de "H" plat, CRF.
 In "H"-vorm, vlak, CRF.
 In "H"-Form, flach, CRF.
 En forma de "H" plana, CRF.
 A forma di "H" piatta, CRF.

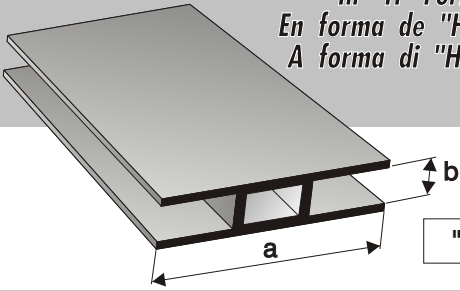

"H" a x b CRF

a (mm)	b (mm)	Weight Poids Gewicht Gewicht Peso Peso (gr/m)	Category Categorie Categorie Kategorie Categorìa Categorìa
30	5	866	4

Q

Lead for lanterns.
 Plomb lanterne.
 Lantaarnlood.
 Laternenblei.
 Plomo para faroles.
 Piombo per appliche.

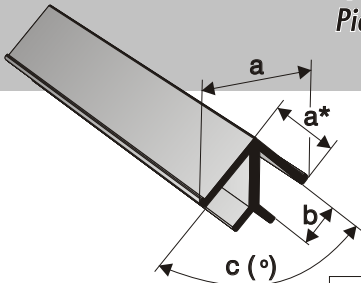

LAN a x b x c

a* (mm)	b (mm)	c (°)	Weight Poids Gewicht Gewicht Peso Peso (gr/m)	Category Categorie Categorie Kategorie Categorìa Categorìa
5.5	3	120	200	3
7	3	90	225	3
a (mm)	b (mm)	c (°)		
10	4	115	190	3
13	4.5	120	218	3
13	4.5	90	311	2
16	4.5	120	245	3

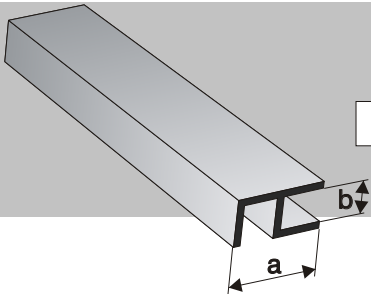

LAN a x b

a (mm)	b (mm)	Weight Poids Gewicht Gewicht Peso Peso (gr/m)	Category Categorie Categorie Kategorie Categorìa Categorìa
10.4	4	220	3

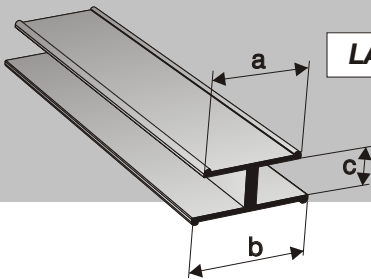

LAN a x b x c

a (mm)	b (mm)	c (mm)	Weight Poids Gewicht Gewicht Peso Peso (gr/m)	Category Categorie Categorie Kategorie Categorìa Categorìa
7	10	4	148	3
10	12	4	178	3

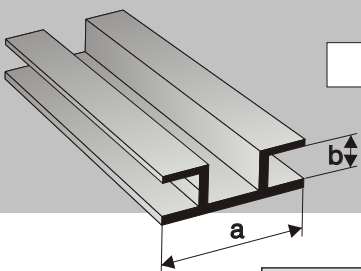

LAN a x b

a (mm)	b (mm)	Weight Poids Gewicht Gewicht Peso Peso (gr/m)	Category Categorie Categorie Kategorie Categorìa Categorìa
19	4.5	516	4



Lead rods.

Baguettes de plomb.
 Loodstaafjes.
 Bleistabe.
 Varillas de plomo.
 Bacchette di piombo.

R

a (mm)	b (mm)	Weight Poids Gewicht Gewicht Peso Peso (gr/m)
4.5	2.5	95

DR 4.5 x 2.5

2.5	2.5	60
-----	-----	----

LISSE 2.5 x 2.5

2.5	2.5	60
-----	-----	----

RAINURE 2.5 x 2.5

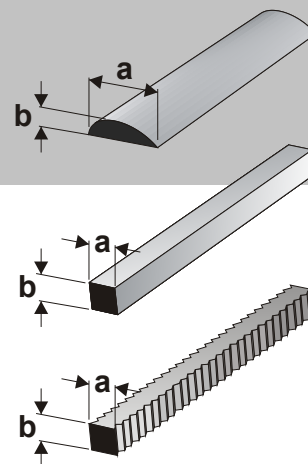

Jointing-lead.

Plomb attache.
 Bindlood.
 Haftenblei.
 Plomo de juntura.
 Piombo per giuntatura.

S

a (mm)	b (mm)	Weight Poids Gewicht Gewicht Peso Peso (gr/m)
5.5	1.2	70

5.5 x 1.2



5.5	2.2	125
-----	-----	-----

5.5 x 2.2



3	2	61
---	---	----

3 x 2

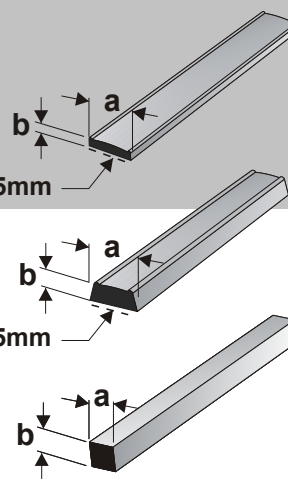

"PLL"

a (mm)	b (mm)	Weight Poids Gewicht Gewicht Peso Peso (gr/m)	Category Catégorie Categorie Kategorie Categoria Categoria
3	12	402	4

"PLL" a x b

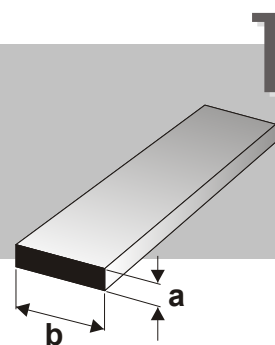

A

In "H" section, flat.
 En forme de "H" plat.
 In "H"-vorm, vlak.
 In "H"-Form, flach.
 En forma de "H" plana.
 A forma di "H" piatta.

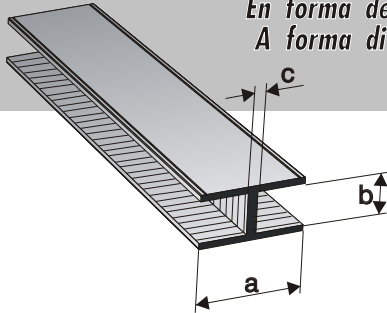

"H" a x b PL - (0.9 / 1.2 / 2)

Thickness of core: **0.9mm**
 Epaisseur d'âme: **0.9mm**
 Zieldikte: **1.2mm**
 Kernstärke: **1.2mm**
 Espesor de alma: **2 mm**
 Spessore d'anima: **2 mm**

5%

EXTRA-SOFT 2m Wooden cases

SOFT HARD HARD

a (mm)	c (mm)	Weight - Poids: Gewicht - Gewicht: (gr/m) Peso - Peso:							Category: Catégorie: Categoria: Categoria:	
		b (mm)								
		3	3.5	4	4.5	5	6	7		
3	0.9	53	59	65	71	77	88		1	
	1.2	64	72	80	88	96	111			
	2	95	107	119	131	143	167	191		
4	0.9	83	89	95	101	107	118			
	1.2	94	102	110	118	126	141			
	2	125	137	149	161	173	197	221		
4.5	0.9	88	94	100	106	112	123			
	1.2	99	107	115	123	131	146			
	2	130	142	154	166	178	202	226		
5	0.9	93	99	105	111	117	128		2	
	1.2	104	112	120	128	136	151			
	2	135	147	159	171	183	207	231		
6	0.9	103	109	115	121	127	138		3	
	1.2	114	122	130	138	146	161			
	2	145	157	169	181	193	217	241		
7	0.9	113	119	125	131	137	148			
	1.2	124	132	140	148	156	171			
	2	155	167	179	191	203	227	251		
8	0.9	128	134	140	146	152	163			4
	1.2	139	147	155	163	171	186			
	2	170	182	194	206	218	242	266		
9	0.9	148	154	160	166	172	183			
	1.2	159	167	175	183	191	206			
	2	190	202	214	226	238	262	286		
10	0.9	158	164	170	176	182	193		5	
	1.2	169	177	185	193	201	216			
	2	200	212	224	236	248	272	296		
11	0.9	178	184	190	196	202	213			
	1.2	189	197	205	213	221	236			
	2	220	232	244	256	268	292	316		
12	0.9	193	199	205	211	217	228			
	1.2	204	212	220	228	236	251			
	2	235	247	259	271	283	307	331		
14	0.9	223	229	235	241	247	258		6	
	1.2	234	242	250	258	266	281			
	2	265	277	289	301	313	337	361		
15	0.9	243	249	255	261	267	278			
	1.2	254	262	270	278	286	301			
	2	285	297	309	321	333	357	381		
16	0.9	263	269	275	281	287	298			
	1.2	274	282	290	298	306	321			
	2	305	317	329	341	353	377	401		
18	0.9	288	294	300	306	312	323			
	1.2	299	307	315	323	331	346			
	2	330	342	354	366	378	402	426		
20	0.9	323	329	335	341	347	358			
	1.2	334	342	350	358	366	381			
	2	365	377	389	401	413	437	461		

**LEAD PROFILES, READY FOR USE, RIBBED.
 PROFILES EN PLOMB ETIRE RAINURE.
 GETROKKEN LODEN PROFIELLEN, GERIBD.
 FENSTERBLEI-PROFILE, GEZOGEN, GERILLT.
 PERFILES DE PLOMO ESTIRADO RANURADO.
 PROFILATI DI PIOMBO TRAFILATO RIGATO.**

2

In "H" section, oval.

En forme de "H" oval.

In "H"-vorm, ovaal.

In "H"-Form, oval.

En forma de "H" oval.

A forma di "H" ovale.

B

a (mm)	c (mm)	Weight - Poids: Gewicht - Gewicht: (gr/m) Peso - Peso:							Category: Catégorie: Kategorie: Categoria: Categoria:
		b (mm)							
		3	3.5	4	4.5	5	6	7	
3	0.9	73	79	85	91	97	108		1
	1.2	84	92	100	108	116	131		
	2	115	127	139	151	163	187	211	
4.5	0.9	93	99	105	111	117	128		2
	1.2	104	112	120	128	136	151		
	2	135	147	159	171	183	207	231	
5	0.9	98	104	110	116	122	133		3
	1.2	109	117	125	133	141	156		
	2	140	152	164	176	188	212	236	
6	0.9	113	119	125	131	137	148		4
	1.2	124	132	140	148	156	171		
	2	155	167	179	191	203	227	251	
7	0.9	133	139	145	151	157	168		5
	1.2	144	152	160	168	176	191		
	2	175	187	199	211	223	247	271	
8	0.9	173	179	185	191	197	208		6
	1.2	184	192	200	208	216	231		
	2	215	227	239	251	263	287	311	
9	0.9	208	214	220	226	232	243		7
	1.2	219	227	235	243	251	266		
	2	250	262	274	286	298	322	346	
10	0.9	243	249	255	261	267	278		8
	1.2	254	262	270	278	286	301		
	2	285	297	309	321	333	357	381	
12	0.9	268	274	280	286	292	303		9
	1.2	279	287	295	303	311	326		
	2	310	322	334	346	358	382	406	

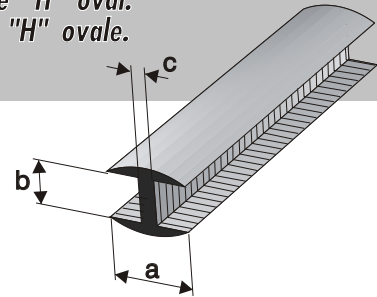

"H" a x b OV - (0.9 / 1.2 / 2)

Thickness of core: **0.9mm**
 Epaisseur d'âme: **1.2mm**
 Zieldikte: **2 mm**
 Kernstärke:
 Espesor de alma:
 Spessore d'anima:

5%

2m



EXTRA-SOFT

1/2 SOFT

1/2 HARD

HARD

**LEAD PROFILES, READY FOR USE, RIBBED.
 PROFILES EN PLOMB ETIRE RAINURE.
 GETROKKEN LODEN PROFIELLEN, GERIBD.
 FENSTERBLEI-PROFILE, GEZOGEN, GERILLT.
 PERFILES DE PLOMO ESTIRADO RANURADO.
 PROFILATI DI PIOMBO TRAFILATO RIGATO.**

2

C

In "H" section, BOR.
 En forme de "H" BOR.
 In "H"-vorm, BOR.
 In "H"-Form, BOR.
 En forma de "H" BOR.
 A forma di "H" BOR.

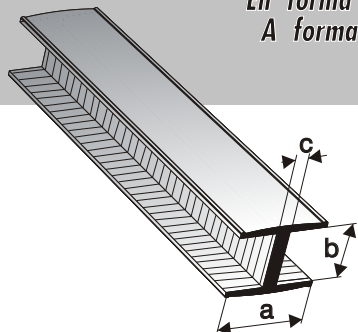

"H" a x b BOR - (0.9 / 1.2 / 2)

Thickness of core:
 Epaisseur d'âme: **0.9mm**
 Zieldicke: **1.2mm**
 Kernstärke: **1.2mm**
 Espesor de alma: **2 mm**
 Spessore d'anima:

a (mm)	c (mm)	Weight - Poids: Gewicht - Gewicht: (gr/m) Peso - Peso:							Category: Catégorie: Kategorie: Categoria: Categoría:
		b (mm)							
		3	3.5	4	4.5	5	6	7	
6	0.9	108	114	120	126	132	143		3
	1.2	119	127	135	143	151	166		
	2	150	162	174	186	198	222	246	
7	0.9	121	127	133	139	145	156		3
	1.2	132	140	148	156	164	179		
	2	163	175	187	199	211	235	259	
8	0.9	135	141	147	153	159	170		4
	1.2	146	154	162	170	178	193		
	2	177	189	201	213	225	249	273	
10	0.9	167	173	179	185	191	202		5
	1.2	178	186	194	202	210	225		
	2	209	221	233	245	257	281	305	
12	0.9	213	219	225	231	237	248		5
	1.2	224	232	240	248	256	271		
	2	255	267	279	291	303	327	351	
14	0.9	258	264	270	276	282	293		6
	1.2	269	277	285	293	301	316		
	2	300	312	324	336	348	372	396	

5%
 2m
 Wooden cases
 EXTRA-SOFT
 SOFT
 HARD
 HARD

D

In "H" section, antique design.
 En forme de "H" antique.
 In "H"-vorm, antiek.
 Karniesblei in "H"-Form.
 En forma de "H" antiguo.
 A forma di "H" antico.

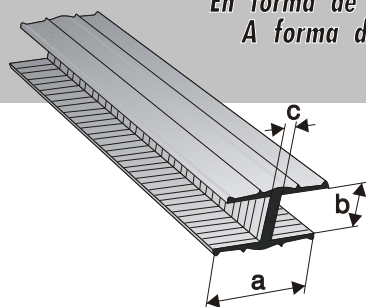

"H" a x b ANTIQUE - (0.9 / 1.2 / 2)

Thickness of core:
 Epaisseur d'âme: **0.9mm**
 Zieldicke: **1.2mm**
 Kernstärke: **1.2mm**
 Espesor de alma: **2 mm**
 Spessore d'anima:

a (mm)	c (mm)	Weight - Poids: Gewicht - Gewicht: (gr/m) Peso - Peso:							Category: Catégorie: Kategorie: Categoria: Categoría:
		b (mm)							
		3	3.5	4	4.5	5	6	7	
8	0.9	148	154	160	166	172	183		4
	1.2	159	167	175	183	191	206		
	2	190	202	214	226	238	262	286	
10	0.9	178	184	190	196	202	213		5
	1.2	189	197	205	213	221	236		
	2	220	232	244	256	268	292	316	
12	0.9	223	229	235	241	247	258		5
	1.2	234	242	250	258	266	281		
	2	265	277	289	301	313	337	361	
15	0.9	288	294	300	306	312	323		6
	1.2	299	307	315	323	331	346		
	2	330	342	354	366	378	402	426	

5%
 2m
 Wooden cases
 EXTRA-SOFT
 SOFT
 HARD
 HARD

REINFORCED LEAD PROFILES, LAMINATED, READY FOR USE, PLAIN, with hardened or non-hardened steel wire.
PROFILES EN PLOMB ARME, LAMINE LISE, avec fil d'acier trempé ou non trempé.
GEBRUIKSKLARE PROFIELEN IN GEWAPEND LOOD, GLAD, met geharde of niet-geharde staaldraad.
STAHLKERNBLEI, GLATT, mit gehärteter oder ungehärteter Stahldraht.
PERFILES DE PLOMO, ARMADO, LAMINADO LIÑO, con alambre de acero templado o no.
PROFILATI DI PIOMBO ARMATO, LAMINATO LISCIO, con filo d'acciaio temperato o no.

3

a (mm)	b (mm)	Total weight Poids total Totaalgewicht Gesamtgewicht Peso total Peso totale (gr/m)
8	4.5	215
8	5	220
9	4.5	228
9	5	234
10	4.5	230
10	5	245
12	4.5	268
12	5	280
15	5	325

Flat reinforced lead (steel wire of 4 x 1.5mm).
Plomb armé plat (fil d'acier de 4 x 1.5mm).
Vlak gewapend lood (staaldraad van 4 x 1.5mm).
Flaches Stahlkernblei (Stahleinlage von 4 x 1.5mm).
Plomo armado plano (con alambre de acero de 4 x 1.5mm).
Piombo armato piatto (filo d'acciaio da 4 x 1.5mm).

A

"H" ARME a x b PL

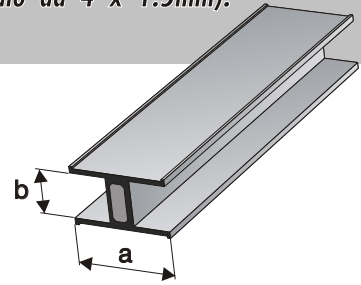

a (mm)	b (mm)	Total weight Poids total Totaalgewicht Gesamtgewicht Peso total Peso totale (gr/m)
10	5	355
12	5	405
15	5	460

Oval reinforced lead (steel wire of 4 x 1.5mm).
Plomb armé oval (fil d'acier de 4 x 1.5mm).
Ovaal gewapend lood (staaldraad van 4 x 1.5mm).
Ovales Stahlkernblei (Stahleinlage von 4 x 1.5mm).
Plomo armado oval (con alambre de acero de 4 x 1.5mm).
Piombo armato ovale (filo d'acciaio da 4 x 1.5mm).

B

"H" ARME a x b OV

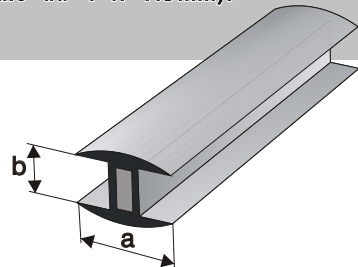

a (mm)	b (mm)	Total weight Poids total Totaalgewicht Gesamtgewicht Peso total Peso totale (gr/m)
8	4.5	275
8	5	315
10	4.5	287
10	5	323
12	4.5	325
12	5	340

Reinforced lead, strengthened (steel wire of 5 x 2mm).
Plomb armé renforcé (fil d'acier de 5 x 2mm).
Versterkt gewapend lood (staaldraad van 5 x 2mm).
Verstärktes Stahlkernblei (Stahleinlage von 5 x 2mm).
Plomo armado reforzado (alambre de acero de 5 x 2mm).
Piombo armato rafforzato (filo d'acciaio da 5 x 2mm).

C

"H" ARME RENFORCE a x b

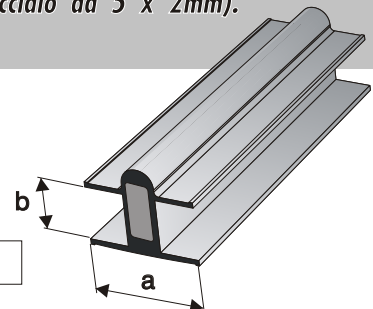

D

*Antique reinforced lead (steel wire of 4 x 1.5mm).
 Plomb armé antique (fil d'acier de 4 x 1.5mm).
 Antiek gewapend lood (staaldraad van 4 x 1.5mm).
 Karnies Stahlkernblei (Stahleinlage von 4 x 1.5mm).
 Plomo armado antiguo (con alambre de acero de 4 x 1.5mm).
 Piombo armato antico (filo d'acciaio da 4 x 1.5mm).*

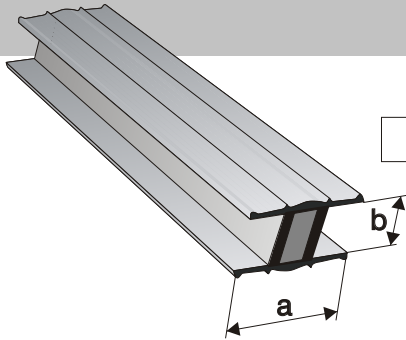

"H" ARME a x b ANTIQUE

a (mm)	b (mm)	Total weight Poids total Totaalgewicht Gesamtgewicht Peso total Peso totale (gr/m)
8	4.5	219
8	5	233
10	4.5	255
10	5	267
12	4.5	275
12	5	306
15	4.5	314
15	5	348



E

*Reinforced lead in "U" section, HEAVY
 (steel wire of 4 x 1.5mm).
 Plomb armé, en forme de "U" LOURD
 (fil d'acier de 4 x 1.5mm).
 Gewapend lood in "U"-vorm, ZWAAR
 (staaldraad van 4 x 1.5mm).*

*Stahlkernblei in "U"-Form, SCHWER
 (Stahleinlage von 4 x 1.5mm).
 Plomo armado en forma de "U" PESADO
 (alambre de acero de 4 x 1.5mm).
 Piombo armato a forma di "U" PESANTE
 (filo d'acciaio da 4 x 1.5mm).*

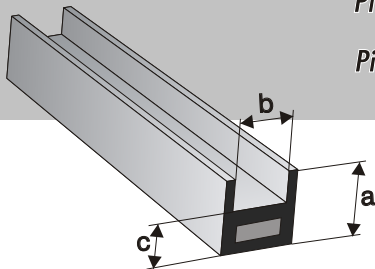

"U" Lourd ARME a x b x c

a (mm)	b (mm)	c (mm)	Total weight Poids total Totaalgewicht Gesamtgewicht Peso total Peso totale (gr/m)
10	5	5	420



F

*Round iron rods covered with plain lead.
 Vergettes rondes en acier recouvertes de plomb lisse.
 Ronde stalen roeden overtrokken met glad lood.
 Runde Windeisen aus Stahl mit Bleiüberzug.
 Varillas redondas de acero revestidas con plomo liso.
 Verghette rotonde d'acciaio ricoperte di piombo liscio.*

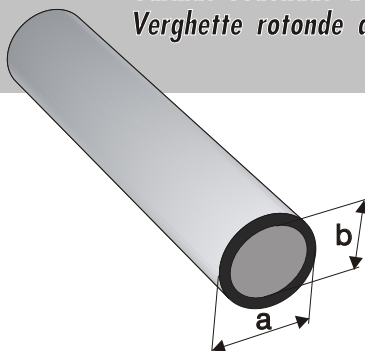

VERGETTE ACIER a x b

a (mm)	b (mm)	Total weight Poids total Totaalgewicht Gesamtgewicht Peso total Peso totale (gr/m)
9	6	620
11	8	900
13	10	1270



**ROUGH SOLID LEAD PROFILES.
PROFILES EBAUCHE EN PLOMB LISSE.
BREUKLOOD, GLAD.
BRUCHBLEI, GEPRESST.
PERFILES DE PLOMO BRUTO MACIZO, LISO.
PROFILATI DI PIOMBO GREZZO LISCIO.**

4

*Rough solid lead profiles, plain execution.
Profils ébauche en plomb lisse, plein.
Vol breuklood, glad.
Volles bruchblei, gepresst.
Perfiles de plomo bruto macizo, liso.
Profilati di piombo grezzo liscio, pieno.*

A

a (mm)	b (mm)	c (mm)	Weight Poids Gewicht Peso Peso (gr/m)	Category Catégorie Categorie Kategorie Categoria
4.5	3.6	2.5	157	1
4.5	4.6	2.5	197	
4.5	6	2.5	248	
7.5	3.6	2.5	220	2
7.5	4.6	2.5	290	
7.5	6	2.5	300	2
8	3.8	2.5	394	
10	3.7	2.5	288	2
10	4.6	2.5	309	
10	6	2.5	420	2
13	3.7	2.5	366	
13	4.6	2.5	410	
13	6	2.5	477	2
15.5	3.7	2.5	450	
15.5	4.6	2.5	464	
15.5	6	2.5	510	2
18.5	3.7	2.5	542	
18.5	4.6	2.5	585	
18.5	6	2.5	630	2
10	4.8	3	520	

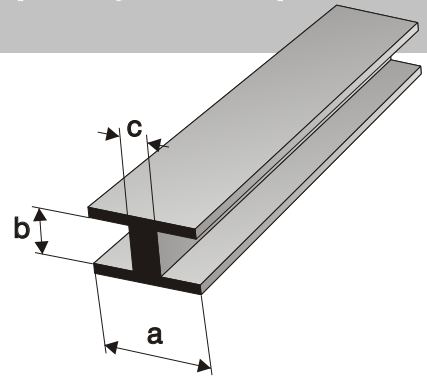

"H" EBAUCHE a x b x c

30Kg
 Cardboard box
 1.2m
 Wooden cases

5%
 1/2 SOFT
 1/2 HARD
 HARD

a (mm)	b (mm)	Weight Poids Gewicht Peso Peso (gr/m)
8.5	5.2	470
11	5.2	545

*Plain rough lead profiles, with hollow core.
Profils ébauche en plomb lisse, à âme creuse.
Breuklood, glad, met holle ziel.
Bruchblei mit hohlkern, gepresst.
Perfiles de plomo bruto macizo, liso, con alma hueca.
Profilati di piombo grezzo liscio, con anima vuota.*

B

SCN a x b

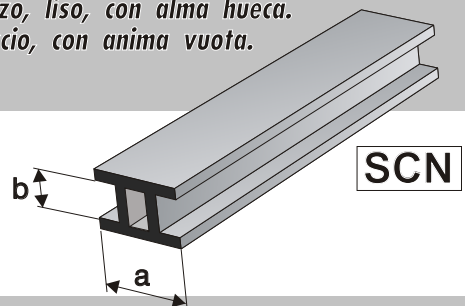

a (mm)	b (mm)	Weight Poids Gewicht Peso Peso (gr/m)
8.5	5	535
11	5	650

SCR a x b

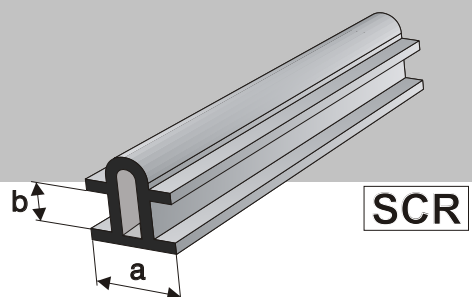

5%
 1/2 SOFT
 30Kg
 Cardboard box

C *Hardened or non-hardened steel wire, in lengths of 2m.
 Fil d'acier trempé ou non trempé, en longueurs de 2m.
 Geharde of niet-geharde staaldraad, in lengten van 2m.
 Gehärteter oder ungehärteter Stahldraht, in längen von 2m.
 Alambre de acero, templado o no, en largos de 2m.
 Filo d'acciaio temperato o no, in barre da 2m.*

*For normal reinforced lead (steel wire of 4 x 1.5mm).
 Pour plomb armé normal (fil d'acier de 4 x 1.5mm).
 Voor normaal gewapend lood (staaldraad 4 x 1.5mm).
 Für normales Stahlblei (Stahldraht von 4 x 1.5mm).
 Para plomo armado normal (alambre de acero de 4 x 1.5mm).
 Per piombo armato normale (filo d'acciaio da 4 x 1.5mm).*

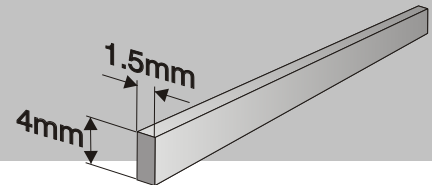

*For reinforced lead, strengthened (steel wire of 5 x 2mm).
 Pour plomb armé renforcé (fil d'acier de 5 x 2mm).
 Voor versterkt gewapend lood (staaldraad 5 x 2mm).
 Für verstärktes Stahlblei (Stahldraht von 5 x 2mm).
 Para plomo armado reforzado (alambre de acero de 5 x 2mm).
 Per piombo armato rafforzato (filo d'acciaio da 5 x 2mm).*

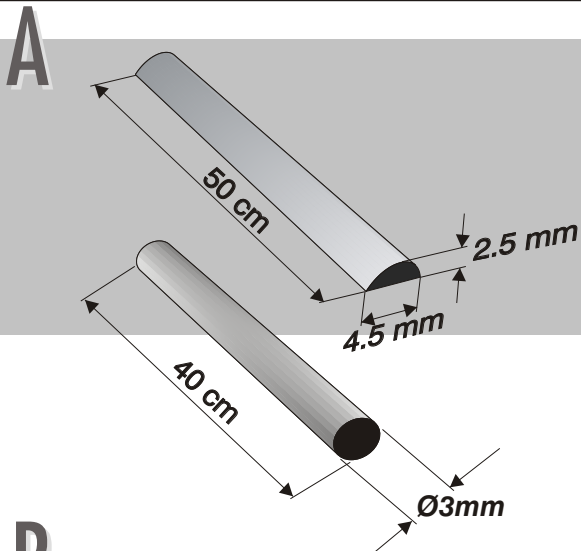
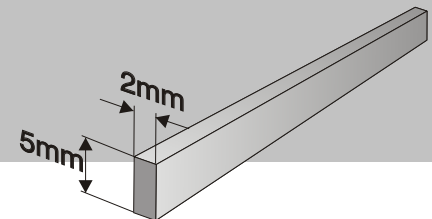

*Plain tin-solder.
 Soudure d'étain lisse.
 Tinsoldeer glad.
 Lötzinn glatt.
 Soldadura de estaño liso.
 Stagno liscio.*

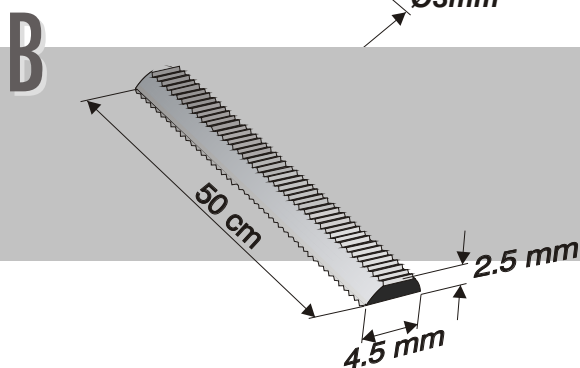

*Ribbed tin-solder.
 Soudure d'étain rainurée.
 Geribd tinsoldeer.
 Lötzinn gerillt.
 Soldadura de estaño ranurado.
 Stagno rigato.*

LEAD STRIPS (with or without adhesive tape).
BANDES DE PLOMB (avec ou sans bande adhésive).
LOODSTRIPS (met of zonder kleefband).
BLEIBÄNDER (mit oder ohne Klebeband).
BANDAS DE PLOMO (con o sin autopegante).
STRISCE DI PIOMBO (con o senza adesivo).

6

a (mm)	b (mm)	Weight Poids Gewicht Gewicht Peso Peso (gr/m)	Adhesive tape Bande adhésive Kleefband Klebeband Autopegante Adesivo (mm)
5.5	1.2	70	5
7	0.5	36	6
10	0.5	60	9
12	0.5	70	11
12	0.8	97	11
15	0.5	83	14
15.5	0.8	133	14

Weight per metre without self - adhesive tape.
 Poids au mètre sans bande adhésive.
 Gewicht per meter zonder kleefband.
 Gewicht pro Meter ohne Klebeband.
 Peso por metro sin autopegante.
 Peso/metro senza adesivo.

"Flat".
 "Plat".
 "Vlak".
 "Flach".
 "Plano".
 "Piatta".

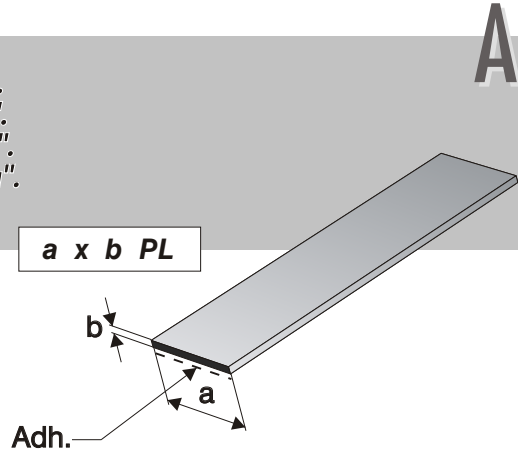

a (mm)	b (mm)	Weight Poids Gewicht Gewicht Peso Peso (gr/m)	Adhesive tape Bande adhésive Kleefband Klebeband Autopegante Adesivo (mm)
6.3	0.8	48	6
7	1.2	70	6
9.5	0.7	53	9
9.5	1.3	107	9
12	0.8	90	11
15	0.8	110	14

Weight per metre without self - adhesive tape.
 Poids au mètre sans bande adhésive.
 Gewicht per meter zonder kleefband.
 Gewicht pro Meter ohne Klebeband.
 Peso por metro sin autopegante.
 Peso/metro senza adesivo.

"Half-round".
 "Demi rond".
 "Half rond".
 "Halbrund".
 "Semi redondo".
 "Mezzo tondo".

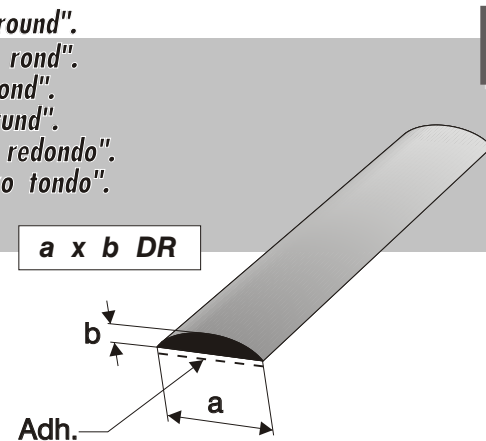

Adhesive:
Adhésif:
Kleefstof:
Klebstoff:
Adhesivo:
Adesivo:

4965

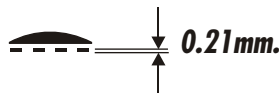

20 N/25 mm

- Glass, Steel, ABS, Synthetic lacquer.
- Verre, Acier, ABS, Laque synthétique.
- Glas, Staal, ABS, Synthetische lak.

- Glas, Stahl, ABS, Synthetischer Lack.
- Vidrio, Acero, ABS, Laca sintética.
- Vetro, Acciaio, ABS, Lacca sintetica.

200 °C
 (short intervals).
 (de courte durée).
 (kortstondig).
 (von kurzer Dauer).
 (de corta duración).
 (tempo breve).



80 °C
 (permanent).
 (permanente).
 (beständig).
 (beständig).
 (permanente).
 (permanente).

LEAD STRIPS (with or without adhesive tape).
BANDES DE PLOMB (avec ou sans bande adhésive).
LOODSTRIPS (met of zonder kleefband).
BLEIBÄNDER (mit oder ohne Klebeband).
BANDAS DE PLOMO (con o sin autopegante).
STRISCE DI PIOMBO (con o senza adesivo).

6

"CAN" - (Fluted)
 (Cannelé)
 (Gegolfd)
 (Kanneliert)
 (Acanalado)
 (Scanalato)

a	b	Weight Poids Gewicht Peso Peso	Adhesive tape Bande adhésive Kleefband Klebeband Autopegante Adesivo
(mm)	(mm)	(gr/m)	(mm)
30	5	188	30
30	4.29	160	30
30	3	180	30

Weight per metre without self - adhesive tape.
Poids au mètre sans bande adhésive.
Gewicht per meter zonder kleefband.
Gewicht pro Meter ohne Klebeband.
Peso por metro sin autopegante.
Peso/metro senza adesivo.

a CAN (6 x b)
 (7 x b)
 (10 x b)

Re 30m

Re 15Kg

Cardboard box

5%

1/2 SOFT

1/2 HARD

Adhesive:
Adhésif:
Kleefstof:
Klebstoff:
Adhesivo:

DUPLOCOLL 3720

0.13mm.

20 N/25 mm

- Glass, Steel, ABS, Synthetic lacquer.
- Verre, Acier, ABS, Laque synthétique.
- Glas, Staal, ABS, Synthetische lak.

- Glas, Stahl, ABS, Synthetischer Lack.
- Vidrio, Acero, ABS, Laca sintética.
- Vetro, Acciaio, ABS, Lacca sintetica.

120 °C

(short intervals).
(de courte durée).
(kortstondig).
(von kurzer Dauer).
(de corta duracion).
(tempo breve).

100 °C

(permanent).
(permanente).
(bestendig).
(beständig).
(permanente).
(permanente).

PLAIN LEAD PROFILES, COATED WITH BRASS, RED COPPER, GERMAN SILVER AND ANODISED OR LACQUERED ALUMINIUM .
PROFILES EN PLOMB LISSE RECOUVERTS DE LAITON, CUIVRE ROUGE, MAILLECHORT ET D'ALUMINIUM ANODISE OU LAQUE.
LODEN PROFIELEN, GLAD, OVERTROKKEN MET MESSING, ROODKOPER, NIEUWZILVER EN GEANODISEERD OF GELAKT ALUMINIUM.
BLEIPROFILE, GEPRESST, MIT MESSING-, ROTKUPFER-, NEUSILBERÜBERZUG UND ELOXIERTEM ODER LACKIERTEM ALUMINIUMÜBERZUG.
PERFILES DE PLOMO LISO, REVESTIDOS CON LATÓN, COBRE ROJO, PLATA ALEMANA Y ALUMINIO ANODIZADO O LACADO.
PROFILATI DI PIOMBO LISCIO RICOPERTI DI OTTONE, RAME ROSSO, ALPACCA ED ALLUMINIO ANODIZZATO O LACCATO.

7

AL

- Coatings:
- Recouvrements :
- Ommantelingen :
- Ummantelungen :
- Recubrimientos :
- Rivestimenti :

1

- Polished aluminium :
- Aluminium poli :
- Gepolijst aluminium :
- Aluminium poliert :
- Aluminium pulido :
- Alluminio lucido :

- gold, silver, red copper anodised.
- anodisé or, argent, cuivre rouge.
- goud, zilver, roodkoper geänodiseerd.
- gold, silber, rotkopper eloxiert.
- anodizado oro, plata, cobre rojo.
- anodizzato oro, cromo, rame rosso.

2

- Brushed aluminium :
- Aluminium brossé :
- Geborsteld aluminium :
- Aluminium gebürstet :
- Aluminium cepillado :
- Alluminio satinato :

- gold, silver, red copper, champagne, black anodised.
- anodisé or, argent, cuivre rouge, champagne, noir.
- goud, zilver, roodkopper, champagne, zwart geänodiseerd.
- gold, silber, rotkopper, champagne, schwarz eloxiert.
- anodizado oro, plata, cobre rojo, champán, negro.
- anodizzato oro, cromo, rame rosso, champagne, nero.

3

- Lacquered aluminium :
- Aluminium laqué :
- Gelakt aluminium :
- Aluminium lackiert :
- Aluminium laqueado :
- Alluminio laccato :

- maroon, white.
- marron, blanc.
- kastanjebruin, wit.
- kastanienbraun, weiss.
- marrón, blanco.
- marrone, bianco.

MET

- Coatings:
- Recouvrements :
- Ommantelingen :
- Ummantelungen :
- Recubrimientos :
- Rivestimenti :

1

- Brass.
- Laiton.
- Messing.
- Messing.
- Latón.
- Ottone.

2

- Red copper.
- Cuivre rouge.
- Roodkoper.
- Rotkupfer.
- Cobre rojo.
- Rame rosso.

3

- German silver.
- Maillechort.
- Nieuwzilver.
- Neusilber.
- Plata alemana.
- Alpacca.

A

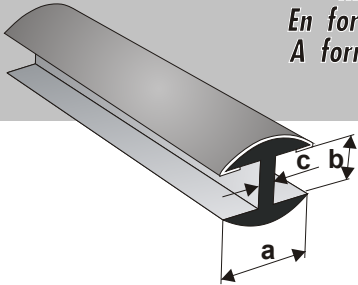

In "H" section, oval.
 En forme de "H" oval.
 In "H"-vorm, ovaal.
 In "H"-Form, oval.
 En forma de "H" oval.
 A forma di "H" ovale.

"H" a x b OV - /

/
 Coated on one side
 recouvert d'un côté
 één zijde ommanteld
 einseitig ummantelt
 revestimiento de un lado
 rivestiti su un lato

MET

AL

a (mm)	b (mm)	c (mm)	Total weight Poids total Totaalgewicht Gesamtgewicht Peso total Peso totale (gr/m)	Total weight Poids total Totaalgewicht Gesamtgewicht Peso total Peso totale (gr/m)
4	3	1.2	113	
4	3.5	1.2	121	112
4	4	1.2	129	120
4	4.5	1.2		128
4	5	1.2	145	136
5	3	1.2	143	
5	3.5	1.2	151	140
5	4	1.2	159	148
5	4.5	1.2		156
5	5	1.2	175	164
6	4	1.2	203	194
6	4.5	1.2		202
6	5	1.2	219	210
8	4	1.2	241	230
8	4.5	1.2		238
8	5	1.2	257	246
10	4	1.2	332	317
10	4.5	1.2		325
10	5	1.2	348	333

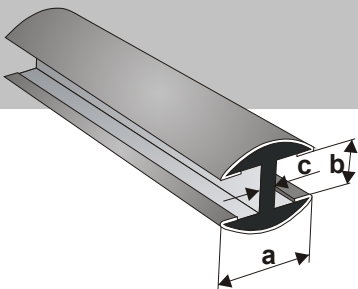

"H" a x b OV - //

//
 Coated on both sides
 recouvert des deux côtés
 beide zijden ommanteld
 beidseitig ummantelt
 revestimiento de ambos lados
 rivestiti su due lati

a (mm)	b (mm)	c (mm)	Total weight Poids total Totaalgewicht Gesamtgewicht Peso total Peso totale (gr/m)	Total weight Poids total Totaalgewicht Gesamtgewicht Peso total Peso totale (gr/m)
3.5	2	1.2	111	
4	3	1.2	126	
4	3.5	1.2	134	116
4	4	1.2	142	124
4	4.5	1.2	150	132
4	5	1.2	158	140
5	3	1.2	159	
5	3.5	1.2	167	145
5	4	1.2	175	153
5	4.5	1.2	183	161
5	5	1.2	191	169
6	3.5	1.2	211	
6	4	1.2	219	201
6	4.5	1.2	227	209
6	5	1.2	235	217
8	3.5	1.2	253	
8	4	1.2	261	239
8	4.5	1.2	269	247
8	5	1.2	277	255
10	4	1.2	357	327
10	4.5	1.2	365	335
10	5	1.2	373	343

MET

AL

5%

2m

3m

Wooden cases

HARD

**PLAIN LEAD PROFILES, COATED WITH BRASS, RED COPPER, GERMAN SILVER AND ANODISED OR LACQUERED ALUMINIUM .
 PROFILES EN PLOMB LISSE RECOUVERTS DE LAITON, CUIVRE ROUGE, MAILLECHORT ET D'ALUMINIUM ANODISE OU LAQUE.
 LODEN PROFIELEN, GLAD, OVERTROKKEN MET MESSING, ROODKOPER, NIEUWZILVER EN GEANODISEERD OF GELAKT ALUMINIUM.
 BLEIPROFILE, GEPRESST, MIT MESSING-, ROTKUPFER-, NEUSILBERÜBERZUG UND ELOXIERTEM ODER LACKIERTEM ALUMINIUMÜBERZUG.
 PERFILES DE PLOMO LISO, REVESTIDOS CON LATÓN, COBRE ROJO, PLATA ALEMANA Y ALUMINIO ANODIZADO O LACADO.
 PROFILATI DI PIOMBO LISCIO RICOPERTI DI OTTONE, RAME ROSSO, ALPACCA ED ALLUMINIO ANODIZZATO O LACCATO.**

7

MET AL

a (mm)	b (mm)	Total weight Poids total Totaalgewicht Gesamtgewicht Peso total Peso totale (gr/m)	Total weight Poids total Totaalgewicht Gesamtgewicht Peso total Peso totale (gr/m)
6	5.5	327	308
8	5.5	396	372

In "Y" section, oval (with lead flange).
 En forme de "Y" oval (talon plomb).
 In "Y"-vorm, ovaal (loden tand).
 In "Y"-Form, oval (mit bleisteg).
 En forma de "Y", oval (con espiga de plomo).
 A forma di "Y" ovale (maschio di piombo).

B

Coated on one side
 recouvert d'un côté
 één zijde ommanteld
 einseitig ummantelt
 revestimiento de un lado
 rivestiti su un lato

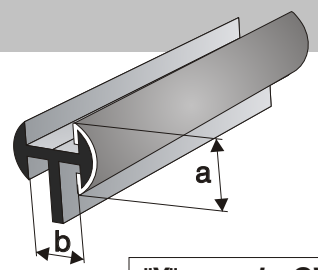

"Y" a x b OV - /

MET AL

a (mm)	b (mm)	Total weight Poids total Totaalgewicht Gesamtgewicht Peso total Peso totale (gr/m)	Total weight Poids total Totaalgewicht Gesamtgewicht Peso total Peso totale (gr/m)
6	5	358	320
8	5	435	387

Coated on both sides
 recouvert des deux côtés
 beide zijden ommanteld
 beidseitig ummantelt
 revestimiento de ambos lados
 rivestiti su due lati

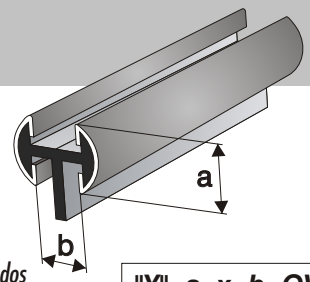

"Y" a x b OV - //

MET AL

5%
 2m
 3m
 Wooden cases
 HARD

MET AL

a (mm)	b (mm)	Total weight Poids total Totaalgewicht Gesamtgewicht Peso total Peso totale (gr/m)	Total weight Poids total Totaalgewicht Gesamtgewicht Peso total Peso totale (gr/m)
5	3	148	
5	4	172	121
8	4	274	226

In "C" section, oval.
 En forme de "C" oval.
 In "C"-vorm, ovaal.
 In "C"-Form, oval.
 En forma de "C", oval.
 A forma di "C" ovale.

C

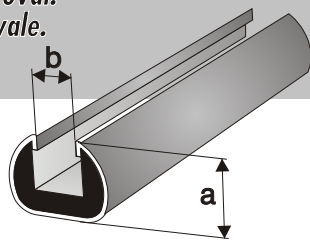

"C" a x b OV

MET AL

5%
 2m
 3m
 Wooden cases
 HARD

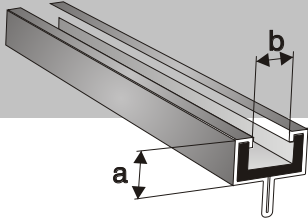
D

In "Y" section, flat.
 En forme de "Y" plat.
 In "Y"-vorm, vlak.
 In "Y"-Form, flach.
 En forma de "Y", plana.
 A forma di "Y" piatta.

MET

a (mm)	b (mm)	Total weight Poids total Totaalgewicht Gesamtgewicht Peso total Peso totale (gr/m)
5	4	166

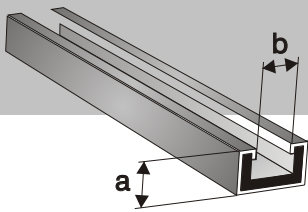
"Y" a x b PL**E**

In "U" section, flat.
 En forme de "U" plat.
 In "U"-vorm, vlak.
 In "U"-Form, flach.
 En forma de "U", plana.
 A forma di "U" piatta.

MET

a (mm)	b (mm)	Total weight Poids total Totaalgewicht Gesamtgewicht Peso total Peso totale (gr/m)
5	4	148
6	4	176

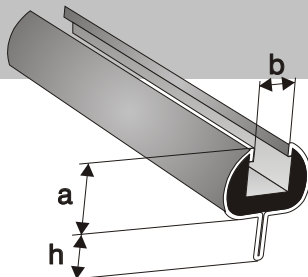
"U" a x b PL**F**

In "Y" section, oval.
 En forme de "Y" oval.
 In "Y"-vorm, ovaal.
 In "Y"-Form, oval.
 En forma de "Y", oval.
 A forma di "Y" ovale.

MET

a (mm)	b (mm)	h (mm)	Total weight Poids total Totaalgewicht Gesamtgewicht Peso total Peso totale (gr/m)
6	3.5	6	221
6	3.5	5	180
4	3	5	142
4	4	5	156
5	3	5	170
5	4	5	181
6	4	5	206
6	5	5	233
8	4	5	263
8	5	5	282
5	3	4	164

"Y" a x b x h OV

PLAIN LEAD PROFILES, COATED WITH BRASS, RED COPPER, GERMAN SILVER AND ANODISED OR LACQUERED ALUMINIUM .
PROFILES EN PLOMB LISSE RECOUVERTS DE LAITON, CUIVRE ROUGE, MAILLECHORT ET D'ALUMINIUM ANODISE OU LAQUE.
LODEN PROFIELEN, GLAD, OVERTROKKEN MET MESSING, ROODKOPER, NIEUWZILVER EN GEANODISEERD OF GELAKT ALUMINIUM.
BLEIPROFILE, GEPRESST, MIT MESSING-, ROTKUPFER-, NEUSILBERÜBERZUG UND ELOXIERTEM ODER LACKIERTEM ALUMINIUMÜBERZUG.
PERFILES DE PLOMO LISO, REVESTIDOS CON LATÓN, COBRE ROJO, PLATA ALEMANA Y ALUMINIO ANODIZADO O LACADO.
PROFILATI DI PIOMBO LISCIO RICOPERTI DI OTTONE, RAME ROSSO, ALPACCA ED ALLUMINIO ANODIZZATO O LACCATO.



MET

a (mm)	b (mm)	c (mm)	Total weight Poids total Totaalgewicht Gesamtgewicht Peso total Peso totale (gr/m)
4	3	1.2	102
4	3.5	1.2	104
4	4	1.2	106
5	3	1.2	124
5	4	1.2	128
6	4	1.2	148
8	4	1.2	188
12	4	1.2	268

In "H" section, flat.
 En forme de "H" plat.
 In "H"-vorm, vlak.
 In "H"-Form, flach.
 En forma de "H" plana.
 A forma di "H" piatta.

"H" a x b x c PL - /

/

Coated on one side
 recouvert d'un côté
 één zijde ommanteld
 einseitig ummantelt
 revestimiento de un lado
 rivestiti su un lato

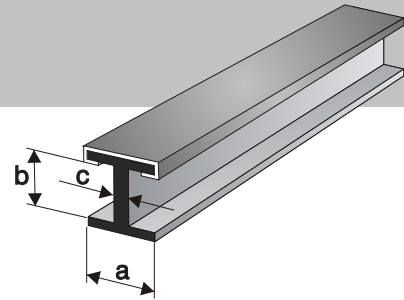

G

MET

a (mm)	b (mm)	c (mm)	Total weight Poids total Totaalgewicht Gesamtgewicht Peso total Peso totale (gr/m)
4	3	1.2	116
4	3.5	1.2	118
4	4	1.2	120
5	3	1.2	142
5	4	1.2	146
6	4	1.2	168
8	4	1.2	212
12	4	1.2	297

"H" a x b x c PL - //

//

Coated on both sides
 recouvert des deux côtés
 beide zijden ommanteld
 beidseitig ummantelt
 revestimiento de ambos lados
 rivestiti su due lati

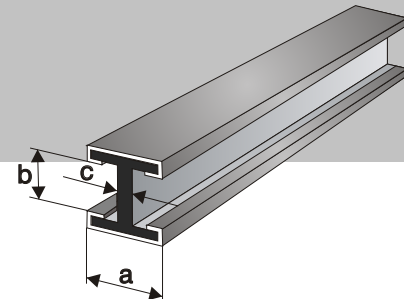

5%
 2m
 Wooden cases
 HARD

MET

a (mm)	b (mm)	c (°)	Total weight Poids total Totaalgewicht Gesamtgewicht Peso total Peso totale (gr/m)
13	4.5	90	367

Lead for lanterns.
 Plomb lanterne.
 Lantaarnlood.
 Laternenblei.
 Plomo para faroles.
 Piombo per appliche.

LAN a x b x c

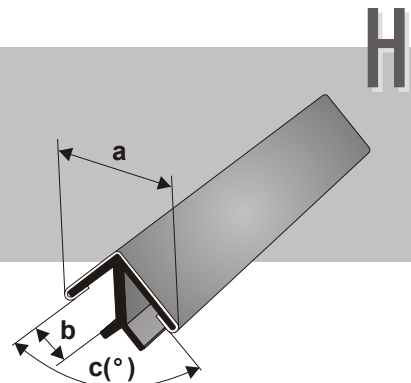

H

5%
 2m
 Wooden cases
 HARD

PLAIN LEAD PROFILES, COATED WITH BRASS, RED COPPER, GERMAN SILVER AND ANODISED OR LACQUERED ALUMINIUM .
 PROFILES EN PLOMB LISSE RECOUVERTS DE LAITON, CUIVRE ROUGE, MAILLECHORT ET D'ALUMINIUM ANODISE OU LAQUE.
 LODEN PROFIELEN, GLAD, OVERTROKKEN MET MESSING, ROODKOPER, NIEUWZILVER EN GEANODISEERD OF GELAKT ALUMINIUM.
 BLEIPROFILE, GEPRESST, MIT MESSING-, ROTKUPFER-, NEUSILBERÜBERZUG UND ELOXIERTEM ODER LACKIERTEM ALUMINIUMÜBERZUG.
 PERFILES DE PLOMO LISO, REVESTIDOS CON LATÓN, COBRE ROJO, PLATA ALEMANA Y ALUMINIO ANODIZADO O LACADO.
 PROFILATI DI PIOMBO LISCIO RICOPERTI DI OTTONE, RAME ROSSO, ALPACCA ED ALLUMINIO ANODIZZATO O LACCATO.



In "Y" section, round.
 En forme de "Y" rond.
 In "Y"-vorm, rond.
 In "Y"-Form, rund.
 En forma de "Y", redonda.
 A forma di "Y" rotonda.

MET

a	b	h	Total weight Poids total Totaalgewicht Gesamtgewicht Peso total Peso totale
(mm)	(mm)	(mm)	(gr/m)
8	3.5	6	389

"Y" a x b x h RD

"Flat".
 "Plat".
 "Vlak".
 "Flach".
 "Plano".
 "Piatta".

MET

Total weight Poids total Totaalgewicht Gesamtgewicht Peso total Peso totale
(gr/m)
78

6.5 x 1.2 PL

"Half-round".
 "Demi rond".
 "Halfrond".
 "Halbrund".
 "Semi redondo".
 "Mezzo tondo".

107

6.5 x 2 DR

Adhesive:
Adhésif:
Kleefstof:
Klebstoff:
Adesivo:

4965

0.21mm.

20 N/25 mm

- Glas, Steel, ABS, Synthetic lacquer.
- Verre, Acier, ABS, Laque synthétique.
- Glas, Staal, ABS, Synthetische lak.

- Glas, Stahl, ABS, Synthetischer Lack.
- Vidrio, Acero, ABS, Laca sintética.
- Vetro, Acciaio, ABS, Lacca sintetica.

200 °C

(short intervals).
 (de courte durée).
 (kortstondig).
 (von kurzer Dauer).
 (de corta duracion).
 (tempo breve).

80 °C

(permanent).
 (permanente).
 (bestendig).
 (beständig).
 (permanente).
 (permanente).

AL & MET

In "H" section, oval.
 En forme de "H" oval.
 In "H"-vorm, ovaal.
 In "H"-Form, oval.
 En forma de "H", oval.
 A forma di "H" ovale.

a	b	c	Total weight Poids total Totaalgewicht Gesamtgewicht Peso total Peso totale
(mm)	(mm)	(mm)	(gr/m)
5	3.2	1.2	187

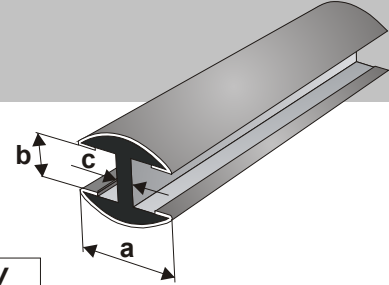

"H" BIMETAL a x b OV



5%



3m



Wooden cases



HARD

AL & MET

In "Y" section, oval.
 En forme de "Y" oval.
 In "Y"-vorm, ovaal.
 In "Y"-Form, oval.
 En forma de "Y", oval.
 A forma di "Y" ovale.

a	b	h	c	Total weight Poids total Totaalgewicht Gesamtgewicht Peso total Peso totale
(mm)	(mm)	(mm)	(mm)	(gr/m)
5	3.2	4	2.5	293

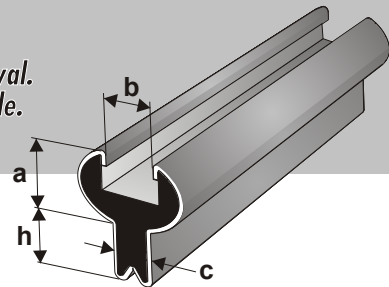

"Y" BIMETAL a x b x h OV



5%



3m



Wooden cases



HARD

- Coatings:
- Recouvrements :
- Ommantelingen :
- Ummantelungen :
- Recubrimientos :
- Rivestimenti :

AL

ANODISED ALUMINUM.
 ALUMINUM ANODISE.
 GEANODISEERD ALUMINIUM.
 ELOXIERT ALUMINIUM.
 ALUMINIO ANODIZADO.
 ALLUMINIO ANODIZZATO.

MET

BRASS, RED COPPER OR GERMAN SILVER.
 LAITON, CUIVRE ROUGE OU MAILLECHORT.
 MESSING, ROODKOPER OF NIEUWZILVER.
 MESSING-, ROTKUPFER- MESSING- ODER NEUSILBERÜBERZUG.
 LATON, COBRE ROJO, O PLATA ALEMANA.
 OTTONE, RAME ROSSO O ALPACCA.

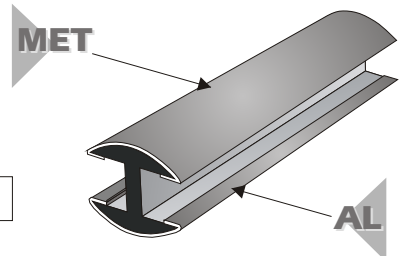

"H" BIMETAL 5 x 3.2 OV

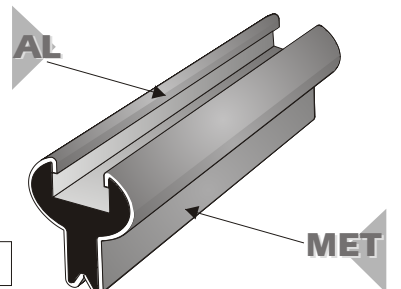

"Y" BIMETAL 5 x 3.2 x 4 OV

A

Tinplate "U" profiles.

"U" en fer blanc.
 "U" - profielen in blik.
 "U" -Leisten aus Weissblech.
 "U" de hojalata.
 "U" in barre.

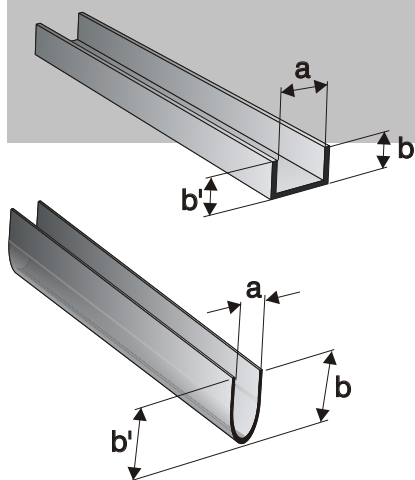

(2m & 51cm)

"U" $b \times a \times b'$

b	a	b'	Weight Poids Gewicht Gewicht Peso Peso
(mm)	(mm)	(mm)	(gr/m)

4	2.5	4	20
4	3	4	20.7
4	4	4	23.7
4	5	4	25.7
6	6	6	34.6

7	2.5	7	29.6
---	-----	---	------



5%



2m



Wooden cases

B

"U" profiles in raw brass, red copper, or german silver.

"U" en laiton brut, cuivre rouge, ou maillechort.
 "U" - profielen in ruw messing, roodkoper, of nieuwzilver.
 "U" -Leisten aus Rohmessing, Rotkupfer, oder Neusilber.
 "U" de latón bruto, cobre rojo o plata alemana.
 "U" in ottone, rame rosso, o alpacca.

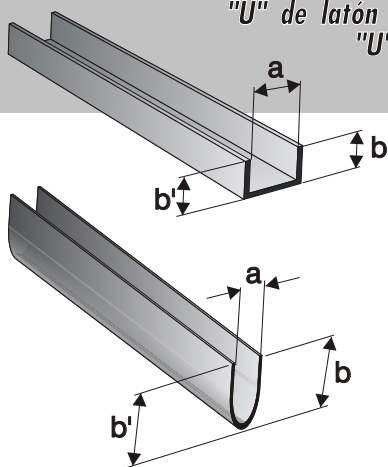

"U" $b \times a \times b'$

b	a	b'	Weight Poids Gewicht Gewicht Peso Peso
(mm)	(mm)	(mm)	(gr/m)

4	2.5	4	23
4	3	4	23.7
4	4	4	27
4	5	4	29.25
6	6	6	39.4

7	2.5	7	33
---	-----	---	----



5%



2m



Wooden cases

C

"U" and "T" profiles in zinc, raw brass, red copper.

"U" et "T" en zinc, laiton brut, cuivre rouge.
 "U" en "T"- profielen in zink, ruw messing, roodkoper.
 "U" und "T"-Leisten aus Zink, Rohmessing, Rotkupfer.
 "U" o "T" de zinc, latón bruto, cobre rojo.
 "U" o "T" in zinco, ottone, o rame rosso.

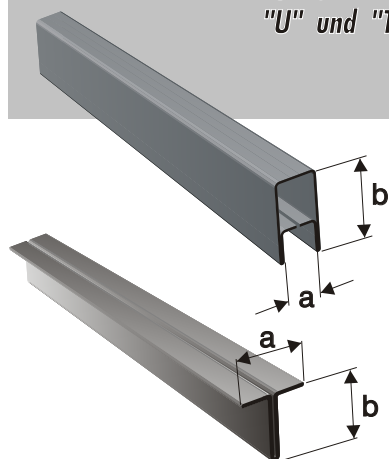

"U" $a \times b$

"U"

a	b	Weight Poids Gewicht Gewicht Peso Peso
(mm)	(mm)	(gr/m)

4	12.7	175
6	16	232

"T" $a \times b$

"T"

8.7	10	114
-----	----	-----



5%



2m



Wooden cases

A

- NORMAL PACKAGING
- CONDITIONNEMENT NORMAL
- NORMALE VERPAKKING
- NORMALE VERPACKUNG
- EMBALAJE CORRIENTE
- CONDIZIONAMENTO CORRENTE

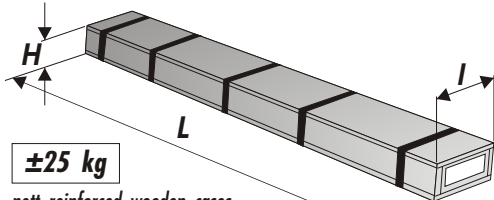

±25 kg

nett reinforced wooden cases.
net caisses bois renforcé.
netto versterkte houtden kisten.
netto verstärkte Holzkisten.
neto cajas de madera reforzadas.
netti casse in legno rafforzate.

	PAL
L	2100
H	40
I	155

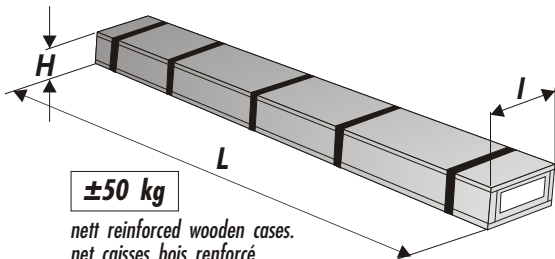

±50 kg

nett reinforced wooden cases.
net caisses bois renforcé.
netto versterkte houtden kisten.
netto verstärkte Holzkisten.
neto cajas de madera reforzadas.
netti casse in legno rafforzate.

	MAL2M	MAL3M
L	2090	3100
H	80	100
I	150	155

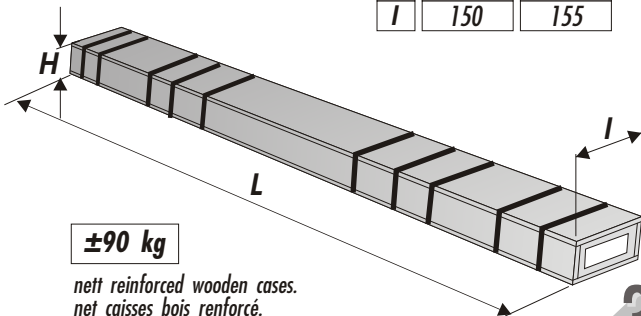

±90 kg

nett reinforced wooden cases.
net caisses bois renforcé.
netto versterkte houtden kisten.
netto verstärkte Holzkisten.
neto cajas de madera reforzadas.
netti casse in legno rafforzate.

	GAL2M	GAL3M
L	2090	3100
H	80	115
I	150	185

- Each box is provided with a sticker, showing details of contents.
- Chaque caisse est munie d'une étiquette, mentionnant les caractéristiques du contenu.
- Elke kist is voorzien van een etiket met details over de inhoud.
- Jede Kiste ist mit einem Aufkleber mit Einzelheiten über den Inhalt versehen.
- Cada caja está provista de una etiqueta, mencionando las características del contenido.
- Ogni cassa viene provvista di una etichetta, con le varie caratteristiche del contenuto.

L = external dimension (mm).
= dimensions extérieures (mm).
= buitenmaten (mm).
H = Außenabmessungen (mm).
= dimensiones exteriores (mm).
I = dimensioni esterne (mm).

B

- SPECIAL PACKAGING FOR DISTRIBUTORS
- CONDITIONNEMENT SPECIAL POUR DISTRIBUTEURS
- SPECIAL VERPAKKING VOOR VERDELERS
- SONDERVERPACKUNG FÜR GROSHANDLER
- EMBALAJE ESPECIAL PARA DISTRIBUIDORES
- CONDIZIONAMENTO SPECIALE PER DISTRIBUTORI

±25 kg

nett, light cases.

Minimum quantity: 20 cases, binded together.

net, caisses légères.

Quantité minimale: 20 caisses, cerclées ensemble.

netto, lichte kisten.

Minimum hoeveelheid: 20 kisten, samengebonden.

netto, leichte kisten.

Mindestmenge: 20 kisten, gebündelt.

neto, cajas ligeras.

cantidad mínima: 20 cajas, sujetadas juntas.

netti, casse leggere.

Quantità minima: 20 casse attaccate insieme.

±50 kg

nett, light cases.

Minimum quantity: 10 cases, binded together.

net, caisses légères.

Quantité minimale: 10 caisses, cerclées ensemble.

netto, lichte kisten.

Minimum hoeveelheid: 10 kisten, samengebonden.

netto, leichte kisten.

Mindestmenge: 10 kisten, gebündelt.

neto, cajas ligeras.

cantidad mínima: 10 cajas, sujetadas juntas.

netti, casse leggere.

Quantità minima: 10 casse attaccate insieme.



N.V. STILLEMANS S.A.

BELGIUM

CUSTOMER :

DATE :

CUSTOMER :

ADDRESS :

PARCEL Nr :

ORDER Nr :

CODE Nr :

Gross weight (KG) :

Net weight (KG) :

ITEM REF :



Cascade Metals
1614 West 75th Avenue
Vancouver, British Columbia V6P 6G2
Canada
North America
Toll Free Number: 1-877-298-8884
www.cascademetals.com